

Clean the device only using a cloth dampened with water.  
In order to grant a real safety, a gas detector must be coupled to an electro-valve capable of blocking the gas flow in the event of an alarm.

Both the gas unit and the solenoid valve must comply with the law prescriptions in force in the country concerned.

BEAGLE detector can be connected to two types of electro-valve:

- 230V~ Normally Open electro-valve;
- 230V~ Normally Closed electro-valve;

#### WARNING

The installer is reminded to fill in and apply the sticking label supplied with the product by writing the installation date of the product, the date before which the sensor module must be replaced and last time and finally the date before which the entire detector must be replaced.

The latter is stated on 15 solar years from the installation date of the product.

This label must be applied, at installer care, on a visible side of the gas detector once it has been fixed in its typical installation position.

READ CAREFULLY THE INSTRUCTIONS BEFORE REPLACING THE SENSOR DE-ENERGISE THE DEVICE BEFORE REPLACING THE SENSOR	
Installation date of the device:	_____
Next sensor replacement date (1 <sup>st</sup> ):	_____
Next sensor replacement date (2 <sup>nd</sup> ):	_____
Entire device replacement date:	_____
DEVICE LIFETIME:	15 YEARS FROM FIRST INSTALLATION
SENSOR LIFETIME:	5 YEARS

Warning label:

The CO module can be replaced twice only when no faults took place or several times in case of CO module faults (in this case remember to respect the whole detector

#### SENSOR REPLACEMENT

Every five years (max twice) the internal sensor module must be replaced with a new precalibrated sensor module.

The replacement must be done by qualified personnel according to the following instructions:

1. Use the relevant sensor module part: code AC MC01.
2. Remove the power supply from the detector.
3. Remove the detector's panel as shown in Fig. 2.
4. Spot the sensor module to be replaced:

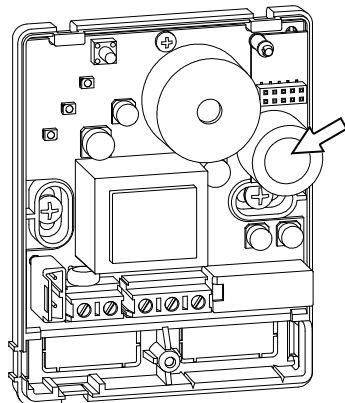

5. Remove the old sensor module.  
For removal just grab the sensor (arrow A) with one hand while grabbing with the other hand the plastic spacer (arrow B) and pull at the same time toward you.

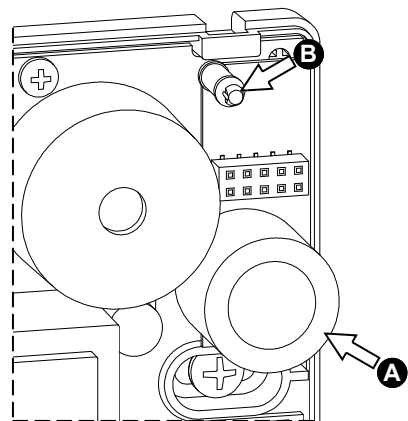

6. Insert the new sensor in the relevant connector. Attention must be paid in that the module's pins match the relevant detector's female connector.

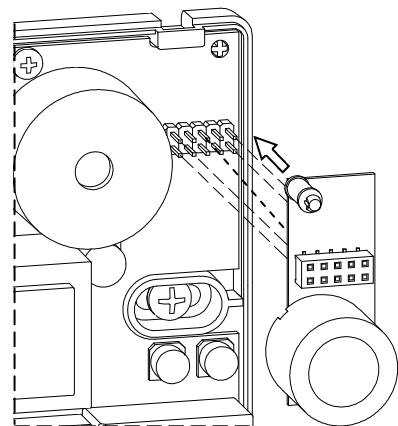

7. Reposition the front panel on the detector and tighten the relevant screw.
8. Power up the detector and check for its correct operation.
9. Fill in the detector's warning label or fill in the new label supplied with the spare sensor module and stick it on the detector.  
Note: that the warning label's date must be 5 years ahead the set up of the new sensor module.

#### WARNING

- Tampering of the device exposes to electrical hazard or malfunction.
- The appliance must be wired to the electric mains through a switch capable of disconnecting all poles in compliant with the current safety standards and with a contact separation of at least 3 mm in all poles.
- Installation and electrical wirings of this appliance must be made by qualified technicians and in compliance with the current standards.
- Before wiring the appliance be sure to turn the mains power off.

#### WARRANTY

In the view of a constant development of their products, the manufacturer reserves the right for changing technical data and features without prior notice.

The consumer is guaranteed against any lack of conformity according to the European Directive 1999/44/EC as well as to the manufacturer's document about the warranty policy.

The full text of warranty is available on request from the seller.

# BEAGLE



## CARBON MONOXIDE DETECTOR ACCUMULATION TYPE

- 230V~ power supply
- Replaceable electrochemical sensor
- Buzzer and relay in case of alarm / fault
- Alarm test / Alarm mute button
- Start counting threshold: 30 ppm (50 mg/m<sup>3</sup>)
- Flush mount over 2 modules junction boxes (square or round shaped) or wall mount using external plastic duct (10x7,5 mm).

Via del Commercio 9/11  
36065 MUSSOLENTE (VI) ITALY  
Tel.: +39.0424.567842  
Fax.: +39.0424.567849  
http://www.seitron.it  
e-mail: info@seitron.it

#### WARNING

##### IN CASE OF ALARM:

- 1) VENTILATE IMMEDIATELY THE ROOM OPENING DOORS AND WINDOWS.
- 2) TURN OFF ANY FUNCTIONING COMBUSTION DEVICE.
- 3) SEARCH AND REMOVE THE POSSIBLE CAUSE OF ALARM.
- 4) IN CASE THE CAUSE OF THE ALARM IS NOT IMMEDIATELY REMOVED, VACATE THE ROOM AND CALL A QUALIFIED TECHNICIAN.

IF THE ALARM STOPS IT IS NECESSARY TO SEARCH THE POSSIBLE CAUSE AND CONSEQUENTLY PROVIDE.

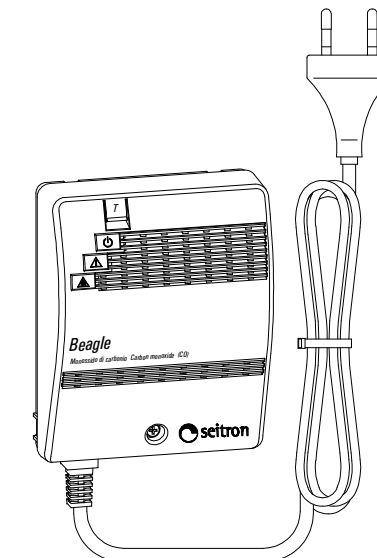

Fig. 1: External aspect.

#### WARNING

THE INSTALLATION OF THE DETECTOR DOESN'T EXEMPT FROM THE OBSERVANCE OF ALL RULES ABOUT THE CHARACTERISTICS, INSTALLATIONS AND THE USE OF THE GAS DEVICES, THE VENTILATION OF THE ROOMS AND THE EMISSIONS OF THE PRODUCTS OF THE COMBUSTION PRESCRIBED FROM UNI STANDARDS AND THE PROVISIONS OF THE LAW.

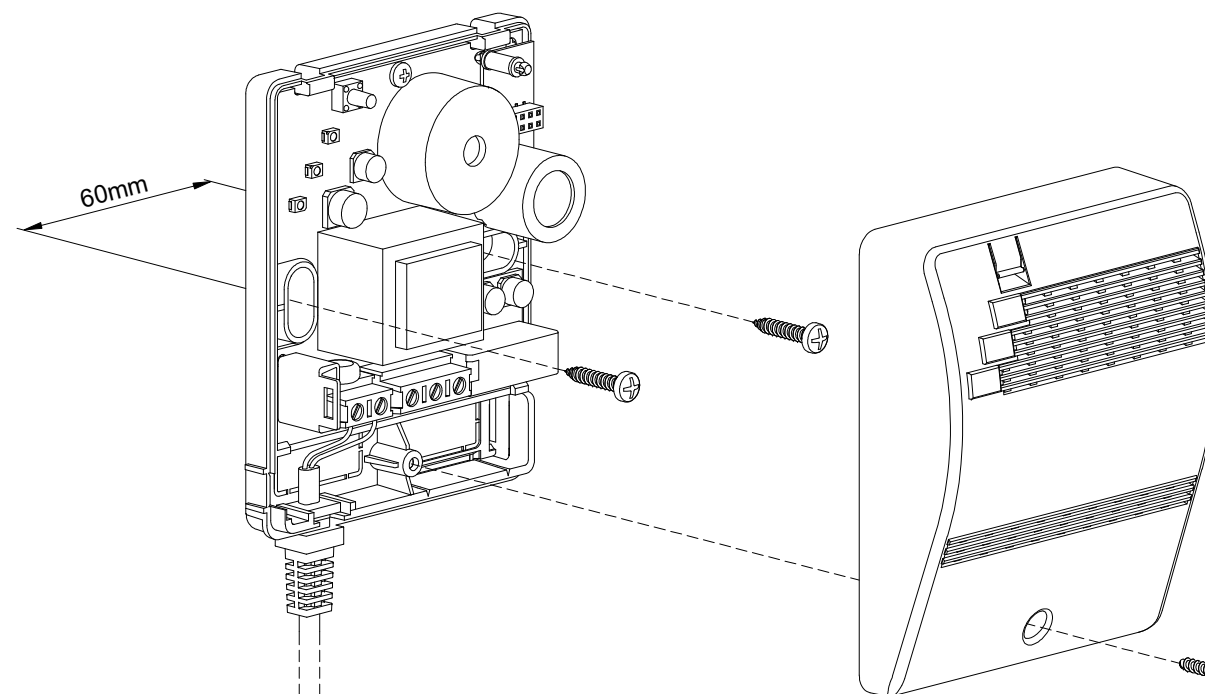

Fig. 2: Installation example.

## WIRING DIAGRAM



### WARNING!

THE GAS DETECTOR MUST BE POWER ONLY BY THE POWER CORD CONNECTED TO THE DEVICE.

IF THE INSTALLATION INCLUDE ALSO A SOLENOID VALVE AND ONE FAN, ELECTRICAL SAFETY AND DEVICE FEATURES ARE GUARANTEED ONLY IF THE ELECTRICAL CONNECTIONS ARE MADE WITH A FIXED WIRING THROUGH THE BOTTOM OPENINGS ON THE PLASTIC BASE (INDICATED WITH THE ARROW IN FIGURE 6) SO THAT THE IP PROTECTION DEGREE IS NOT AFFECTED.

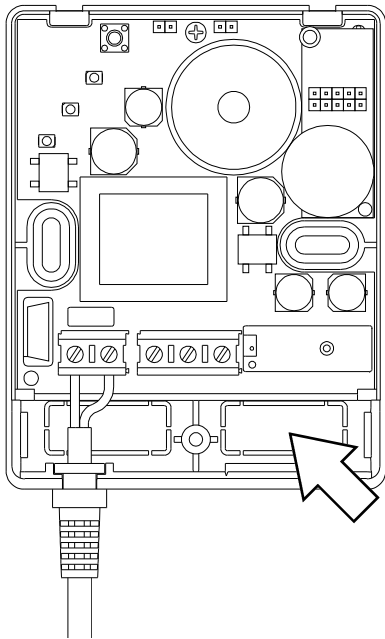

Fig. 3

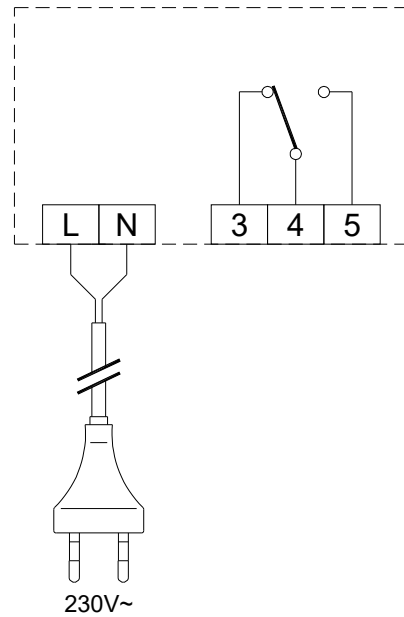

Fig. 4: Wiring diagram of a detector without solenoid valve.

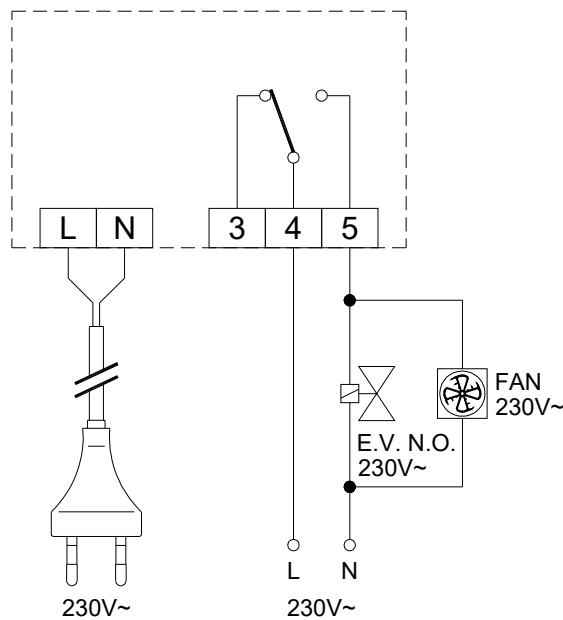

Fig. 5: Wiring diagram with one Beagle and one manual reset Normally Closed 230V~ electro-valve and one 230V~ fan.

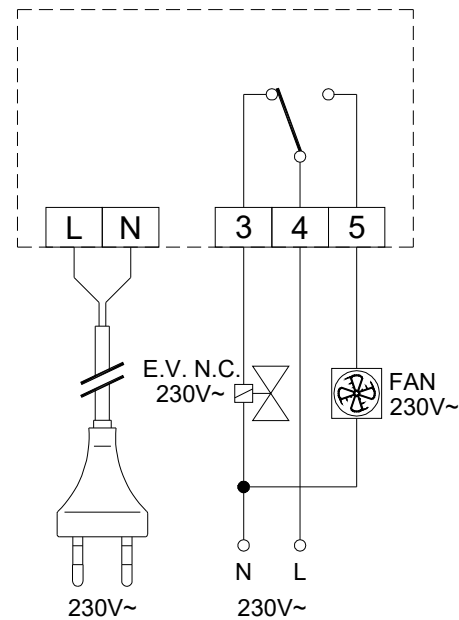

Fig. 6: Wiring diagram with one Beagle and one manual reset Normally Open 230V~ electro-valve and one 230V~ fan.

## TECHNICAL FEATURES

Power supply:	230V~ ±10% 50Hz
Power absorption:	3VA
Sensor type:	Replaceable electrochemical sensor
Detected gas:	CO (Carbon Monoxide)
Start counting threshold:	30 ppm (50 mg/m <sup>3</sup> ) ±5 ppm
Contacts rating:	5(2)A@250V~ SPDT
Indicators:	Active: ◐ Green led on
	Fail: ▲ Yellow led on
	Alarm: ▲ Red led on
	Alarm: Buzzer (after ~15 sec.)
Heating delay at turn-on:	~ 1 minute
Relay activation delay:	~ 30 seconds
Sensor lifetime:	5 years
Operating temperature:	0°C .. 40°C
Storage temperature:	-10°C .. +50°C
Humidity limits:	20% .. 80% RH (non condensing)
Protection rating:	IP 42
Case:	Material: ABS V0 self-extinguishing
	Colour: Signal white (RAL 9003)
Size:	85 x 107 x 38 mm (W x H x D)
Weight:	~ 260 gr.

## OVERVIEW

This detector is a microprocessor based electronic device that answers all needs of safety in those cases in which there can be CO production (e.g. where heating or cooking appliances can have uneven combustions). The device is designed so that it simulates the behaviour of the human body accumulating the gas. The CO gas sensor is replaceable and consists of an electrochemical cell that is also sensitive to acetylene, hydrogen and nitric oxide. Therefore the user must take into account the effect of the cross-sensitivity of the various gases.

Note: Carbon monoxide (CO) is a gas whose high toxicity (it can have severe consequences even when inhaled in very small quantities) is added to an extreme danger because it is not perceptible by people being colourless and odorless.

## OPERATION

### Commissioning

This detector has a built in delay that prevents the alarm to be triggered (thus allowing the sensor to heat up) at power on or when power comes back after a blackout. As soon as it is powered the sensor will perform a diagnostic on the internal circuitry (for a short while all three LEDs turn on) for an electric check; afterwards the sensor will start to stabilize. After the initial delay (about 1 minute) the green LED flashes: when it stops flashing and stays steady the sensor is ready to operate.

### Button 'T'

This is a multifunction key:

### Test function

In order to check the proper operation of the sensor, once the 1 minute stabilization time is completed, just press for 2 seconds the 'T' (test) key, located on the front cover: all green, yellow and red LEDs turn on, while the buzzer activates; at the same time also the relay is energised.

### Internal buzzer mute function

In case of any fault (see section 'Faults') if the key 'T' is shortly pressed, the internal buzzer is muted until a new fault should happen.

In the event of an alarm pressing shortly the 'T' key results in its muting for 5 minutes only.

### Alarm state

When the CO concentration exceeds the 30 ppm (50 mg/m<sup>3</sup>) starts the counting of the intervention time of the device; the intervention time is variable with respect to at the concentration: the higher the concentration, the shorter the intervention time for the alarm.

The intervention time is in compliance with the EN 50291:

CO Concentration	Alarm before	No alarm before
30 ppm	-----	120 minutes
50 ppm	90 minutes	60 minutes
100 ppm	40 minutes	10 minutes
300 ppm	3 minutes	-----

Alarm state is identified with the red LED turned on steady together with the continuous buzzer activation and the output relay energising after ~30 seconds.

The relay can in turn a gas cutoff valve (i.e. a potential in direct CO cause) and/or a fan for the extraction of the poisonous air from the room.

While in this state if the key 'T' is pressed the buzzer is muted for 5 minutes.

The Alarm state is self-resetting in case the CO concentration drops below 25ppm for at least 5 minutes.

## REPLACEABLE CO MODULE

The replaceable CO module is equipped with a microcontroller that monitors continuously the residual life of the electrochemical sensor, and evidencing through the yellow LED (see section 'Faults'), located on the front cover, when the module life is at its end and it must be replaced.

In this case read carefully the section 'CO module replacement'.

## FAULTS

This device features a self-diagnostics for a continuous check of the CO module and the whole detector reliability.

The fault condition is evidenced by a short buzzer activation every 10 seconds, together with the yellow LED flashing in different ways, as described in the following table.

In case the yellow LED is turned on steady and the internal buzzer beeps every 10 seconds, the fault is on the detector board, which must then be replaced.

SIGNAL	FAULT TYPE
n° 1 FLASH	CO module end of life
n° 2 FLASH	CO module fault
n° 3 FLASH	CO module end of life - CO module fault

## INSTALLATION

This device is intended for wall mount only, with relevant electrical wiring made through the fixed wiring, not exposed to people and connected to the fixed electrical wiring. The device safety and operational features are only granted when the electrical wiring is made through the proper opening for cables located in the plastic plate. To access to the internal terminals, remove the front panel by loosening the screw (Fig. 2). Make the electrical wiring following the suggested wiring diagrams in Fig. 4, 5 or 6. Please note that the intervention delay is strictly dependant both on a correct positioning of the detector in the room and to the type of gas to be detected. For "light" gases like CO it is advised to install the device in an high position (about 180 cm from the floor). Please avoid to install this gas detector in any position in which its operational features could be compromised, such as the following:

- in an enclosed space (e.g. in a cupboard or behind a curtain;
- directly above a sink;
- above or close to the cooking board;
- next to a door or window;
- next to an extractor fan;
- in an area where the temperature may drop below - 10°C or exceed + 40°C;
- where dirt and dust may block the sensor;
- in a damp or humid location.

Do not use the following substances in the device immediate adjacency:

- alcohol, fuels
- solvents and diluents
- adhesives, silicones products and colours
- cleaning detergents
- perfumes
- spray products in general