

Gas detection unit



CONTACT US
customer.care@seitron.it

WHATSAPP
+39 329 1444390



- Manages transmitters for combustible, toxic, refrigerant gases
- 8 4 .. 20 mA inputs
- Serial RS485 communication according to MODBUS® protocol (controls up to 32 transmitters)
- 5 relay outputs with voltage-free changeover contacts:
2 alarm relays - 1 pre-alarm relay - 2 auxiliary relays.
- Stores the last alarm conditions.

TECHNICAL FEATURES

Supply voltage:	85 .. 264 V~ , 50 .. 60 Hz or 12 .. 24 V== (through backup system)
Absorbed power:	30 W max
Contact rating of relay outputs:	5 x 8 A 250 V~ cosφ=1 (SPDT) Voltage-free contacts
Inputs:	8 x 4 .. 20 mA
Communication port:	RS485
Communication protocol:	MODBUS® RTU
Start-up time:	related to the warm-up time of the connected transmitters
Transmitters type:	for combustible, toxic, refrigerant gases
Adjustment range:	related to the gas sensor transmitted data
Accuracy:	related to the gas sensor transmitted data
Resolution:	related to the gas sensor transmitted data
Cross sensitivities:	see remote sensor manual.
Protection degree:	IP54
ATEX Protection:	This control unit IS NOT approved for installation in ATEX classified areas.
Operating temperature:	-20 °C .. +55 °C
Storage temperature:	-20 °C .. +55 °C
Humidity limits:	20% .. 90% RH (non-condensing)
Pressure:	800 .. 1100 hPa
Case:	Material: Technopolymer
	Color: Gray (RAL 7035)
Dimensions:	198,4 x 276,7 x 95,8 mm (L x A x P)

WARRANTY

The user is guaranteed against the product's defects of conformity according to European Directive 2019/771 as well as the Seitron warranty terms, available online on the website www.seitron.com. We invite the user to visit our website and check the latest version of technical documents, manuals and catalogs.

RYE01M0001SE 044081 100924

START-UP

- Complete in the following order:**
- Mechanical installation
 - Electrical connections
 - Starting the control unit
 - Scanning connected transmitters
 - Date and time setting

CONTROL UNIT START-UP

As soon as the power supply is applied:

- If the control unit is powered by 85 .. 264 V~ , 50 .. 60 Hz, the "POWER" indicator light light-up steadily;
- If the control unit is powered by 12 .. 24 V== , via a backup system, the "POWER" and "BATTERY" indicator lights light-up steadily.

During the start-up phase, the display shows the following screen:

Gas Master Control	Product name
	Start-up bar
1.0.0	Installed firmware version

After the start-up is completed, the display shows the following screens:

Press the menu button and start a scan.
Press the button to start scanning for connected devices.

Enter password
 0 0 0
 to change the value of the selected digit.
 to select the digit to be changed.
 to confirm the entered password.

Main
Sensors
Relays
System
Test
The display shows the main page of the unit setting menus.

SCAN FOR CONNECTED TRANSMITTERS

Before proceeding with the scan of connected devices, in case a RS485 network has been set up for communication using the MODBUS® RTU protocol between transmitters and the control unit, verify the communication speed of the connected transmitters and, if necessary, correctly set the parameter "System" => "Serial port" => "Speed".

The connected transmitters should have the same communication speed.

The control unit communication speed set by default to 9600 Baud; to modify this data, refer to the complete instruction manual.

Once the auto-learning procedure has started, it cannot be interrupted.

If a setting is changed on any connected transmitter, or the transmitter itself is replaced the scan must be repeated to detect changes.

Procedure:

1. Select the "System" menu and press the button .
2. Select the "Scan" menu and press the button .
3. The display shows the "Scan" line selected. Press the button .
4. As requested by the system, simultaneously press the buttons to start the scan process.
5. The display shows the transmitter scanning screen:



- "C" indicates the position of the transmitter connected to the 4..20 mA input.
- "M" indicates the position of the transmitter connected to the RS485 network.
- "... " indicates querying the presence of the transmitter.
- "x" indicates that the transmitter has not been detected by the control unit.
- "v" indicates that the transmitter has been detected by the control unit.

6. The display shows the message "Scan completed". Press the button .

7. The display shows the selected "Scan" line.

8a. Only transmitters connected to the RS485 network:

Press the button . The display shows the schematic of the connected transmitters.

8b. With 4..20 mA transmitters connected:

- a. Press the button . The display shows the menu of parameters to be set for the first connected 4..20 mA transmitter.
- b. Set all the data proposed by the menu using the buttons .
- c. Once the data for the first transmitter is set, press the button again to move on to setting the data for the next transmitter.
- d. Continue in this manner until all the connected 4..20 mA transmitters data is set.
- e. Once the data for the last transmitter is set, pressing the button will display the schematic of the connected transmitters

MECHANICAL DESCRIPTION

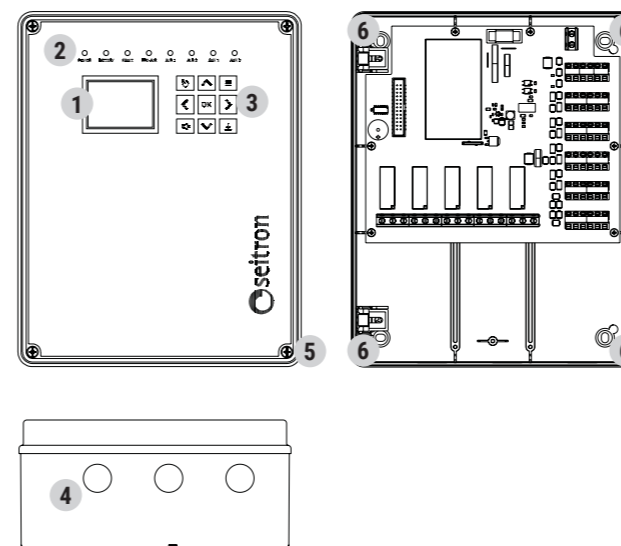

COMPONENTS DESCRIPTION

1	Display
2	Status LED bar
3	Keyboard
	Returns to the previous selection.
	1. Accesses the menus of configurable parameters of the control unit. 2. Under parameter configuration, return to the main screen.
	Alarm silencing.
	Reset alarms.
	Select / Set configurable values.
	Access to submenus / Confirm settings.
4	Holes for mounting the supplied cable glands and/or plugs.
5	Screws for access to the internal parts of the product.
6	Screw seat for fixing the product to the wall.

CONDITIONS OF ACTIVATION OF OUTPUT RELAYS, LEDS AND BUZZER

STATUS	OUTPUTS										RELAY PRE	RELAY AL1	RELAY AL2	RELAY AUX1	RELAY AUX2
	LED POWER	LED BATTERY	LED FAULT	LED PRE-ALR	LED ALR1	LED ALR2	LED AUX1	LED AUX2	BUZZER						
Power supply: 85 .. 264 V~															
Power supply: 12 .. 24 V==, from backup system															
Test LEDs		AC													
Test Relays		AC													
Test Buzzer		AC													
Transmitter fault		AC												AC	AC
Pre-alarm		AC												AC	AC
Alarm 1		AC												AC	AC
Alarm 2		AC												AC	AC
Open loop (solo 4..20 mA)		AC												AC	AC
Over Range		AC												AC	AC
End-of-life sensor		AC												AC	AC

LEGEND

- LED off / Buzzer off / Relay off.
- LED on steady / Buzzer on / Relay activated.
- LED flashing.
- AC** LED lit conditionally (lit steadily if the control unit is powered at 12 .. 24 V==, via backup system)
- AC** Relay conditionally activated; the relay can be activated only if the auxiliary output has been set correctly (see menu "Relays" - "Aux1" and "Aux2").

DATE AND TIME SETTING

The correct setting of date and time is crucial for meaningful logging of the latest alarm event.

This setting must occur during the first activation of the control unit.

Procedure:

1. From the main screen, press the button .
2. Enter the password "1919" to access the menu page.
3. Select the "System" line; press the button .
4. Select the "Clock" line; press the button .
5. Set all the data proposed by the menu using the buttons .
6. Once all the data is set, select the "SAVE" line and press the button .
7. Press the button ; the display shows the schematic of the connected transmitters.

INSTALLATION

- 1 Access the internal parts of the product by unscrewing the 4 screws on the cover.

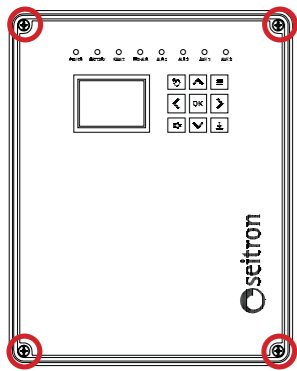

- 2 On the bottom side of the product there are 3 holes each having a diameter of 20.5 mm. The supplied cable glands and/or plugs should be mounted on each hole. The cable glands are used to run the cables for the electrical connections of the product. In case you do not plan to use all the cable glands, it is recommended to mount the plugs in their place.

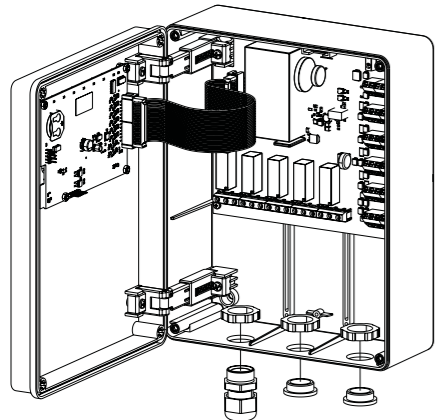

- 3 Locate the four screw slots for fixing the product to the wall. On each drill a hole for inserting the screw.

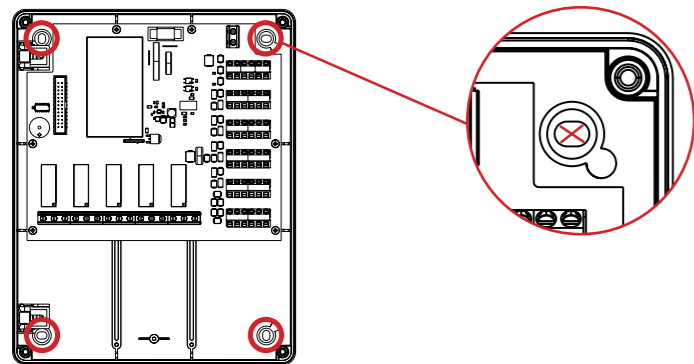

- 4 Secure the product to the wall using the appropriate wall plugs and screws.

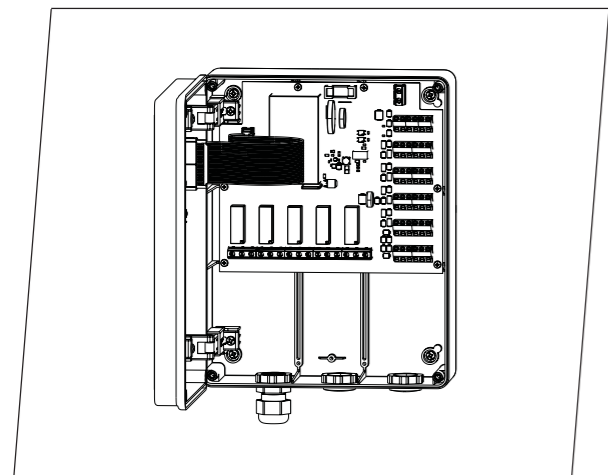

- 5 Make electrical connections; see chapter "Electrical Connections".

- 6 Close the product by tightening the 4 screws on the lid.

ELECTRICAL CONNECTIONS



WARNING

- This control unit IS NOT approved for installation in ATEX classified areas.
- Wiring connections to remote transmitters must be laid out with cables with an appropriate cross-sectional area to ensure proper system sizing, and in any case each wire cross-sectional area must not be less than 1.5 mm². Do not use the same conduit for signal and power cables.
- If the installation is in environments with strong EMC noise, the use of shielded cables is strongly recommended. The shield should be connected to the 'Gnd' terminal of the relevant zone only on the control unit side.
- The control unit and/or power supply unit, if powered at 230 V~, must be connected to the mains via a switch capable of disconnecting both poles, in accordance with current safety standards, and with a separation of at least 3 mm in each pole. In case the control unit is powered at 12 Vdc the note should be extended to the power supply and not to the control unit.
- Installation and electrical connections of this device must be carried out by qualified technicians and in accordance with current technical and safety regulations.
- Before making electrical connections on the control unit, be sure to disconnect power from the system.
- It is the responsibility of the installer (whose responsibility it is to set up a detection system that complies with existing standards, both National and European) to choose the appropriate types of load to be connected to the control unit as well as to correctly configure the system parameters. If in doubt, contact the distributor.

The central unit is normally powered by a 12 Vdc power supply with backup system or by 230 V~ mains voltage. The central unit is equipped with five relays with voltage-free changeover contacts (SPDT): 2 auxiliary relays (AUX 1 and AUX 2), 2 alarm relays (ALR 1 and ALR 2) and one Pre-alarm relay (PRE-ALR). The AUX 1 or AUX 2 outputs can be used either to drive general-purpose loads such as a siren or flashing light or, with proper configuration of related parameters, a gas shut-off solenoid valve. It should be noted that all outputs of the control unit are voltage free, meaning they do not supply power to the loads giving the user greater freedom to use loads with different operating voltages. The RS485 interface is used to connect devices to the control unit. The maximum number of transmitters that can be connected to the control unit with MODBUS® protocol is 32. Refer to the wiring diagram in Fig. 2, Fig. 3, Fig. 4, Fig. 5 and Fig. 6 for the electrical connections.

IMPLEMENTATION OF RS485 NETWORK

RS485 BUS CONNECTION CABLES

Bus connections should be made from a twisted and shielded twisted pair with characteristics equivalent to the BELDEN 9841 or BELDEN 9842 type cables shown in the table below:

TYPE	NO. COUPLES.	DC RESISTANCE		IMPEDANCE NOMINAL (Ohms)	NOMINAL CAPACITY		AWG
		CONDUCTORS (Ohm/km)	SHIELD (Ohm/km)		BETWEEN CONDUCTORS (pF/m)	BETWEEN CONDUCTORS AND SHIELD (pF/m)	
BELDEN 9841	1	78,7	11,0	120	42,0	75,5	24 (0,25 mmq)
BELDEN 9842	2	78,7	7,2	120	42,0	75,5	24 (0,25 mmq)

- The total length of the RS485 network must not exceed 1000 meters.
- The shield of the BUS cable must be connected to ground at only one end, for example, on the peripheral near the control unit. A second ground connection would not ensure equipotentiality of the shield. Do not use the same conduit for both Bus cables and power, or power in general.

POWER CABLES

- Use flame-retardant cable of adequate cross-section according to the devices connected to the control unit; the cross-section should never be less than 2.5mm². Calculate the cable cross-section based on the length and number of connected devices to ensure they fall within the devices' power supply range for proper operation.
- To avoid the use of conductors with a large cross-section, it is possible to power devices point-to-point, using individual power supplies.
- In the RS485 network, it is not necessary to connect the device grounds together.
- In case of communication problems, for example, with point-to-point power supply and devices not electrically grounded, it may be helpful to electrically connect the device grounds together.
- For devices with earth-connected power supply (e.g., PCs), connecting ground and earth together may cause problems.
- The simplicity of RS485 network wiring sometimes leads to overlooking simple precautions, which can sometimes be sources of error, or even the cause of the entire network's communication failure.

EXAMPLES OF WIRING ERRORS

- Routing cables within the same duct.
- Routing cables near strong sources of interference, such as near the power cables of electric motors or contactors.
- Ground and earth cables connected together.
- False contacts or inappropriate electrical connections in junction boxes.
- Use of cables unsuitable for RS485 data transmission, such as untwisted cables.
- Use of inadequate cross-section cables.
- Too high voltage drops on the power cable.

CONTROL UNIT AND LOADS POWERED AT 12.. 24VDC



WARNING

- THE POWER SUPPLY* MUST BE SIZED TO DELIVER AT LEAST 40W OF POWER: IT CAN POWER THE CONTROL UNIT AND 8 TRANSMITTERS OR LOADS.
- THE CONTROL UNIT IS POWERED BY AN EXTERNAL POWER SOURCE AT 12..24VDC. IF A SYSTEM CAPABLE OF TOLERATING POWER FAILURES IS REQUIRED, A 12..24VDC BACKUP GROUP MUST BE PROVIDED. THE +V SUPPLY VOLTAGE FOR GAS TRANSMITTERS IS DERIVED FROM VDC MINUS A FUSE AND A DIODE WITH A TYPICAL VOLTAGE DROP OF 0.3V.

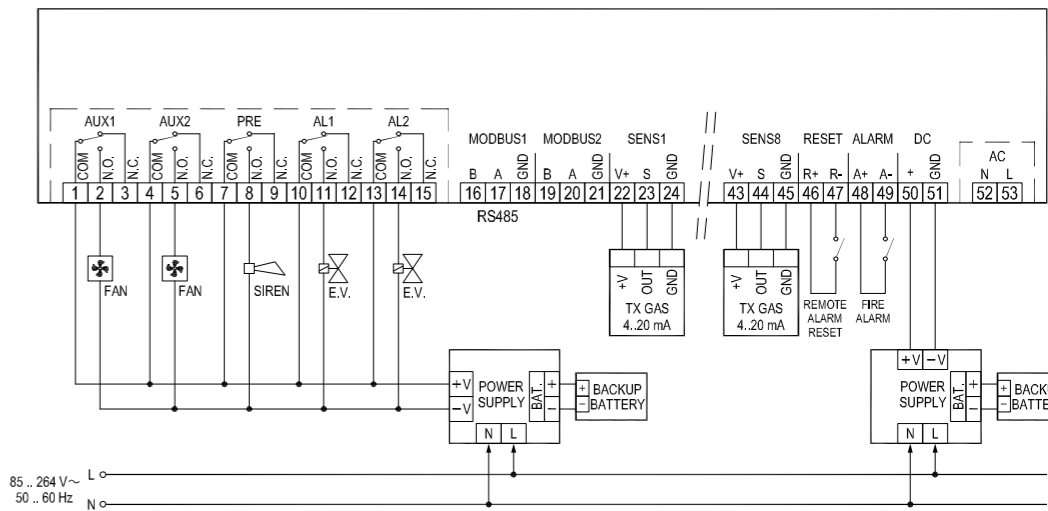

CONTROL UNIT AND LOADS POWERED AT 85 .. 264 V~ 50 .. 60 Hz

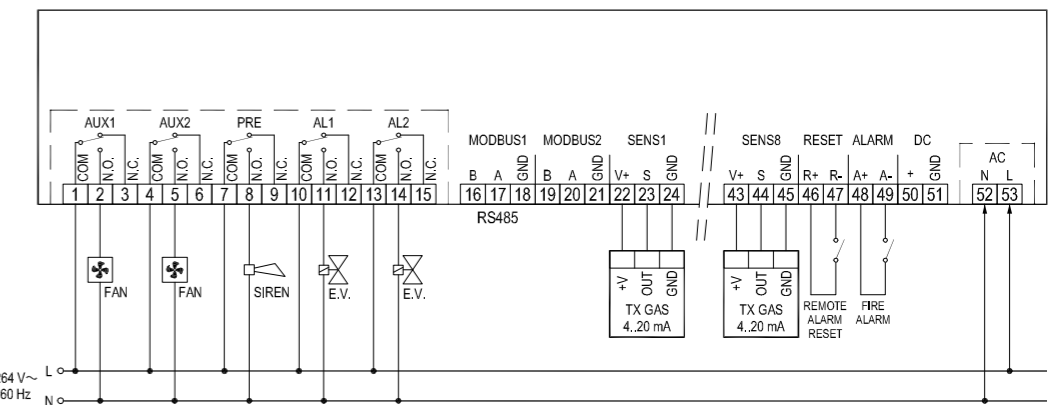

IMPLEMENTATION EXAMPLE OF AN RS485 NETWORK WITH BACKUP POWER SUPPLY AND 32 TRANSMITTERS*

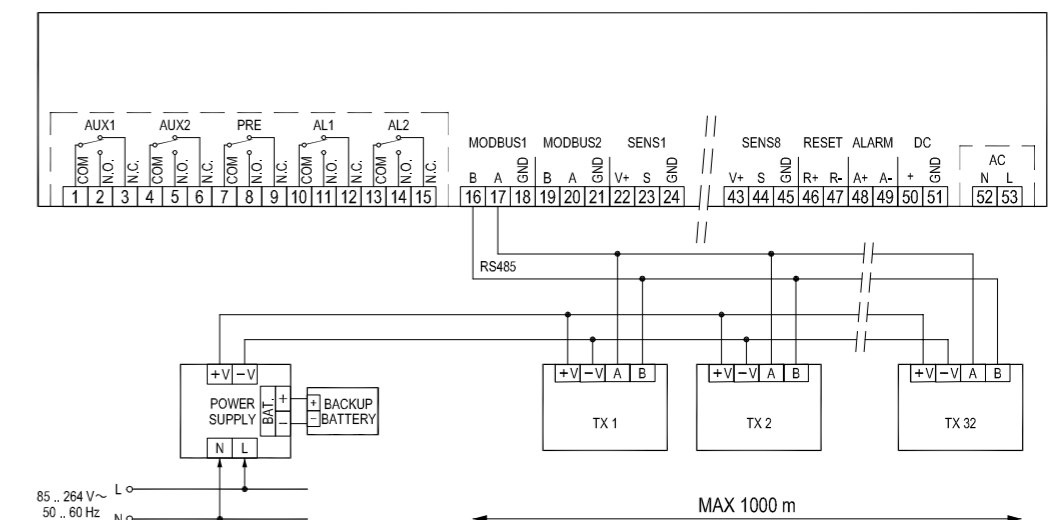

* Check the consistency of the actual system parameters.