

- Remove the 2 screws labelled as 3 in Fig. 1 then remove the plastic cover labelled as 4 in Fig. 1.
- Make the electrical connections as shown in 'Electrical Wiring' below.

- Cable entry can be made in two different ways:

Cable entry from the rear 6:

With the help of a screwdriver, remove the plastic knock-outs from the base, see item 6, Fig. 1. Cables can then be taken through the backplate to the terminal connections.

Cable entry through the top slots in the bottom face 7:

Using pliers, carefully remove the plastic 'teeth' shown arrowed 7, Fig. 2, then after connecting the cable to the appropriate terminal, bend it as shown in Fig. 2 and clamp using the clamps provided.

Cable entry through the lower slots in the bottom face 8:

Pierce the sponge as shown in item 8, Fig. 2, then pass the cable through the sponge into the centre. Make the electrical connections to the appropriate terminals and clamp using the clamps provided.

- Close the device cover, by locating it on the base then screw the 6 closing screws.

ELECTRICAL WIRING

Please read the following carefully and also consult the wiring diagram, Fig. 4, which shows the connection of the power supply and external components to the wiring centre. Terminals L and N are the inputs for the power supply: connect to 230V~, making sure that terminal N is wired to the Neutral.

The centre features a time delayed 8A fuse (F1) (Fig. 3) which protects against short circuit the pump and the transformer plus another time delayed 4A fuse (F2) (Fig. 3) which protects against short circuit all the 24V~ loads (thermostats + actuators) connected to it.

A set of brass terminals is located at the lower left hand side of the base - see Fig. 3.

These are for ensuring earth continuity between the earth conductor in the mains supply cable and any earth conductor for devices connected to the wiring centre e.g. a circulating pump.

Terminals L2 and N2 are the 230V~ powered outputs for connecting the circulating pump.

Terminals NA and C are the outputs for boiler activation.

These are voltage free contacts (unpowered) so that boilers operating with different voltages can be used.

Through terminals L1 N1 SWL NSB a 24V~ external time programmer (optional) can be connected to the wiring centre. Terminals L1 and N1 are the powered outputs for the time programmer power supply, while SWL and NSB are the lines provided for powering the actuators and thermostats section.

For a complete control of each of the available channels the user must connect a 24V~ actuator to terminals L1 and N1 and a 24V~ thermostat to terminals NSB SwL< SwL> TN TL. All outputs of the actuators and thermostats section are 'powered' outputs, i.e. they do provide the voltage for the device connected to them.

Note: each output can drive up to 5 actuators, provided that the power absorption of all actuators connected to the wiring centre is kept within the stated value (see paragraph 'Technical Features'). For the electrical wiring of several actuators please use the cap terminals provided, as shown in Fig. 5.

TECHNICAL FEATURES

- Power supply: 230V~ ±10% 50Hz
- Current absorption: According to the loads rating
- Fuse (F1): 8A Time delayed
- Fuse (F2): 4A Time delayed
- Pump output: 230V~
- Boiler output: Voltage free contact
- Therm./actuators outputs: 24V~
- Time prog. output (optional): 230V~ or 24V~
- Contacts rating:
 - Pump: 5A@250V~ SPST
 - Boiler: 5A@250V~ SPST
- Maximum applicable load:
 - Actuators and thermostats: 2A Total (1,25A each channel)
- Protection index: IP 44
- Operating temp.: 0 .. 40 °C.
- Storage temp.: -10 .. 50 °C
- Humidity limits: 20% .. 80% RH (non condensing)
- Case: Material: ABS UL-V0 self-extinguishing
- Colour: Signal white (RAL 9003)
- Dimensions: 320 x 125 x 67 mm (WxHxD)
- Weight: 2047 gr.

TROUBLESHOOTING

SYMPTOM	CAUSE	REMEDY
LEDs corresponding to the channels output state are turned on, but actuators do not open.	The maximum power allowed for the transformer has been exceeded.	Reduce the number of actuators connected to the wiring centre.
The ON/OFF switch is turned on, yet all LEDs are turned off.	Fuse F1 and/or F2 is blown.	Replace fuse F1 and/or F2 (Fig. 3) with a new equivalent one, same type and rating (see technical features).
Actuators behave the opposite way to that expected.	The wrong contact (NO instead of NC) has been connected on the thermostat.	Correct the wiring on the thermostat.

In the view of a constant development of their products, the manufacturer reserves the right to change technical data and features without prior notice. The consumer is guaranteed against any lack of conformity according to the European Directive 1999/44/EC as well as to the manufacturer's document about the warranty policy. The full text of the warranty is available on request from the seller.

24V, 8 CHANNEL WIRING CENTRE FOR UNDERFLOOR HEATING

- 230V~ power supply
- 230V~ powered output for pump
- 24V~ powered outputs for thermostats, actuators
- 230V~ or 24V~ powered output for external time programmer
- Pump output (with fixed 2.5 min. delay) and boiler interlock output
- Each channel drives one thermostat and up to 5 actuators
- External time programmer input (optional)
- Channel state indication through LEDs

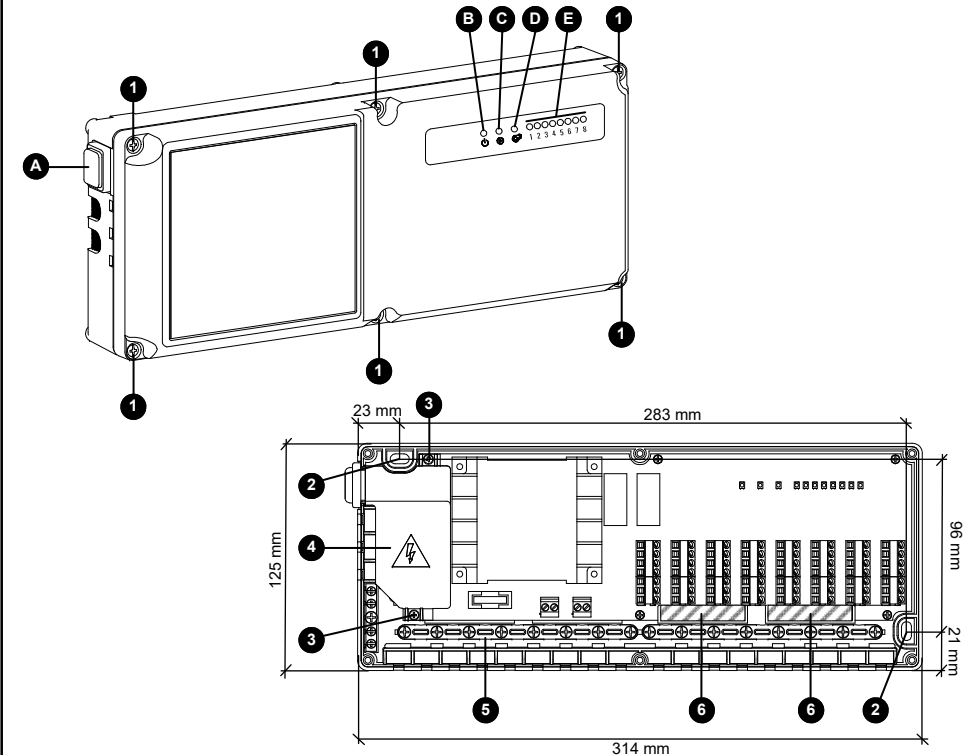

Fig. 1: Internal view and parts.

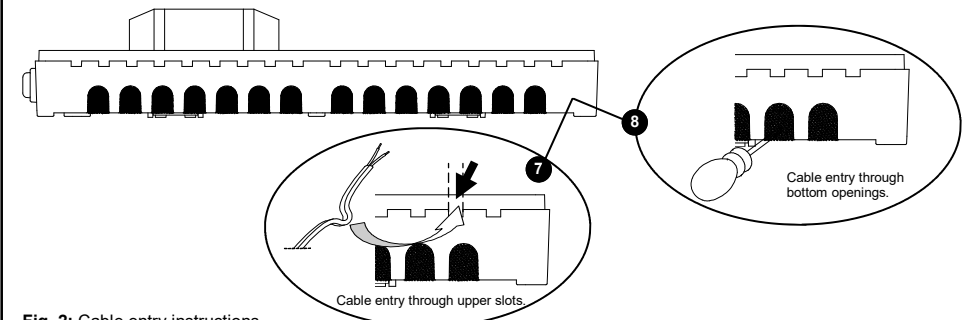

Fig. 2: Cable entry instructions.

ALCD08M020AN 038910 250222

ALCD08M020AN 038910 250222

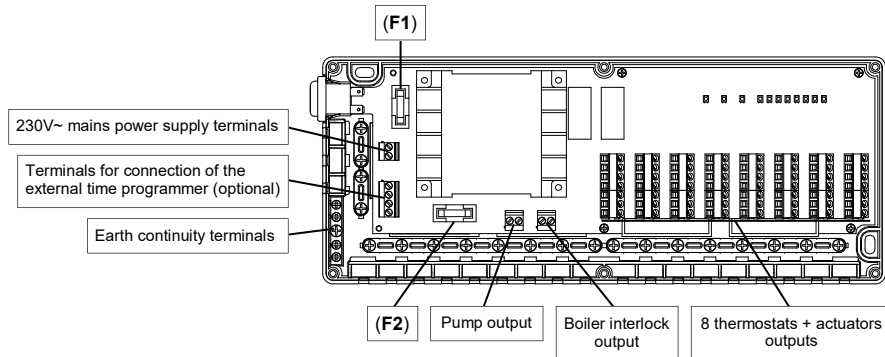
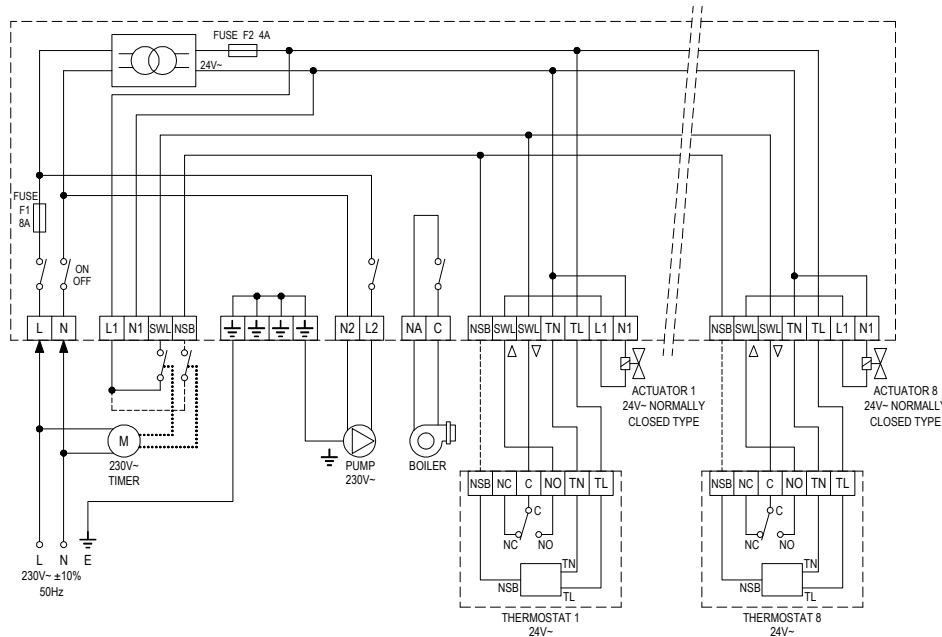

Fig. 3: Internal view of components.



WARNING: WHEN WORKING WITH A 230V TIMESWITCH ON THE 24V WIRING CENTRE, THE CONTROL BOX SWITCH WILL NOT ISOLATE THE POWER SUPPLY TO THE TIMESWITCH. SWITCH OFF THE MAIN ISOLATOR BEFORE WORKING ON THE TIMESWITCH.

Fig. 4: Wiring diagram.

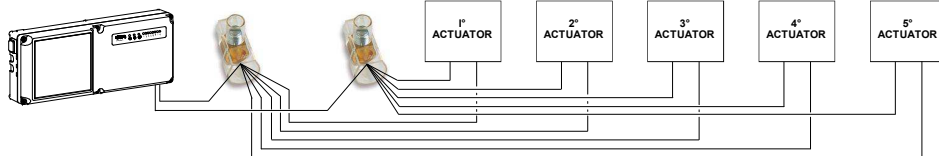

Fig. 5: Wiring example for up to 5 actuators per channel with cap terminals.

WARNING

- The wiring centre must be connected to the power supply through a switch capable of disconnecting all poles in compliance with the current safety standards and with a contact separation of at least 3 mm in all poles.
- Installation and electrical wiring of this wiring centre must be made by a qualified electrician in compliance with the latest edition of BS7671, the IEE Wiring Regulations.
- Before making the mains electrical connections to the wiring centre, be sure to turn off the electricity supply at the main isolator.

OVERVIEW

This device is an 8 channel wiring centre for underfloor heating designed for operation with a 230V mains supply only. **WARNING: THIS WIRING CENTRE MUST ONLY BE USED WITH 24V THERMOSTATS AND ELECTROTHERMIC HEADS.**

Its purpose is to provide the installer with an easy way to interconnect and drive the components normally used in any underfloor heating system, i.e. the connection between thermostats and relevant actuators by sourcing the power from the mains.

The wiring centre features up to 8 channels for thermostats and actuators which are powered with 24V~ from the wiring centre; moreover for each channel one thermostat and up to five actuators can be wired, provided that the overall current absorption is maintained within a maximum value (see 'Technical Features').

Additional features include one pump output, one interlock boiler output and the possibility to connect an external time programmer in order to add a timing to the thermostats operation.

The wiring centre features a time delayed 8A fuse (F1) which protects against short circuit the pump and the transformer plus another time delayed 4A fuse (F2) which protects against short circuit all the 24V~ loads (thermostats + actuators) connected to it.

MECHANICAL DESCRIPTION

On the front panel are located eleven LEDs and one rocker switch (on the left side):

Green LED: power supply 'Ⓢ' (Ⓢ Fig. 1)

This green 'power supply' LED, labeled with the symbol 'Ⓢ', indicates whether the device is turned on or off.

- **LED on:** the device is powered (the side switch is turned in ON position and the light is also turned on).
- **LED off:** the device is unpowered (the side switch is turned in OFF position and the light is also turned off).

Red LED: pump output activation 'Ⓟ' (Ⓟ Fig. 1)

This red LED, labeled with the symbol 'Ⓟ', indicates the state of the pump output relay.

- **LED on:** pump output active (with a fixed, factory set delay - see relevant paragraph); the pump output is activated every time at least one thermostat is calling for heat.
- **LED off:** pump output is inactive.

Red LED: boiler output activation 'Ⓠ' (Ⓠ Fig. 1)

This red LED, labeled with the symbol 'Ⓠ', indicates the state of the boiler output relay.

- **LED on:** boiler output active. The boiler output is immediately activated every time at least one thermostat is calling for heat.
- **LED off:** boiler output is inactive.

Actuator outputs state LEDs '1..8' (Ⓡ Fig. 1)

The status LEDs are 8, each corresponding to a specific actuator output. These indicators (one per each channel) give a visible indication about the request for heat coming from the

relevant thermostat. Each LED indicates the activity or inactivity state of the relevant actuator output.

- **LED on:** the relevant actuator output is active.
- **LED off:** the relevant actuator output is inactive.

ON / OFF illuminated switch (Ⓢ Fig. 1)

The illuminated switch at the lower left hand side of the wiring centre will isolate the whole of the wiring centre except the parts under the plastic cover, item Ⓢ, Fig. 1, to allow access to thermostats and actuators for testing and fault finding during installation. When the switch light is turned on the wiring centre is powered, when it is off the wiring centre is unpowered.

OPERATION

When at least one thermostat connected to the wiring centre is calling for heat, the device immediately activates the boiler output, the relevant channel output and, after a delay of about 2.5 minutes, the pump output (more information in paragraph 'Pump Output').

These outputs are all immediately turned off when no thermostat is calling for heat.

Note: actual actuator's opening and closing time depends on the specific type of actuator installed.

PUMP OUTPUT

When at least one thermostat calls for heat, the device activates, after a 2.5 minutes fixed delay, the pump output. This delay allows the boiler to reach the desired supply water temperature and, at the same time, the full opening of all the actuators driven on before starting the water circulation.

This delay is fixed and cannot be set by the user. Conversely, when no thermostat is calling for heat, the device immediately turns the pump output off.

TIME PROGRAMMER INPUT

This input allows the installer to connect an external 24V~ powered time programmer (optional). This time programmer will turn on and off the entire live wire (SWL) reaching the thermostats, thus turning them on and off according to the time program set by the user.

The NSB terminal allows, once connected to the relevant terminal of a proper thermostat, to set the Night Set Back mode on the thermostat, thus setting it into the 'economy' set-point, which is normally fixed, according to the manufacturer's choice.

INSTALLATION

To install the wiring centre:

- Remove the 6 screws labelled as ❶ in Fig. 1 then remove the front plastic cover.
- Fix the device base to the wall by using the two screw holes labelled ❷ in Fig. 1.
- **When working with electric tools in close proximity to the electronic parts, double check that the device is completely disconnected from 230V~ mains and take care to avoid damaging the circuits or components.**