

IT R011



GSM TELEPHONE INTERFACE

- Working with SIM card supporting 2G technology
- Control via SMS of 2 outputs with SPDT power relay
- Two digital inputs with option of sending SMS alarm messages
- Buffer batteries to send SMS alarm messages when there is no power supply
- Room temperature reading via an external sensor
- Antifrost function
- High reliability level thanks to the automatic reset and re-registration every 24 hours

Via Prodocimo, 30
I-36061 BASSANO DEL GRAPPA (VI)
Tel.: +39.0424.567842
Fax.: +39.0424.567849
<http://www.seitron.it>
e-mail: info@seitron.it

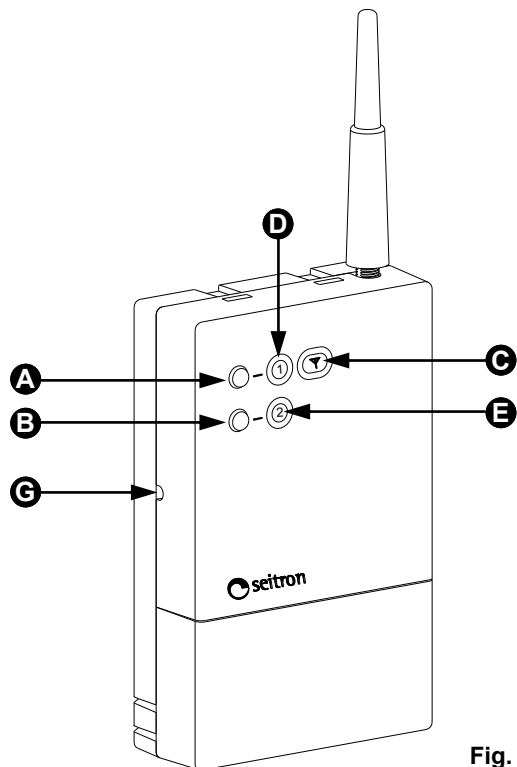

Fig. 1

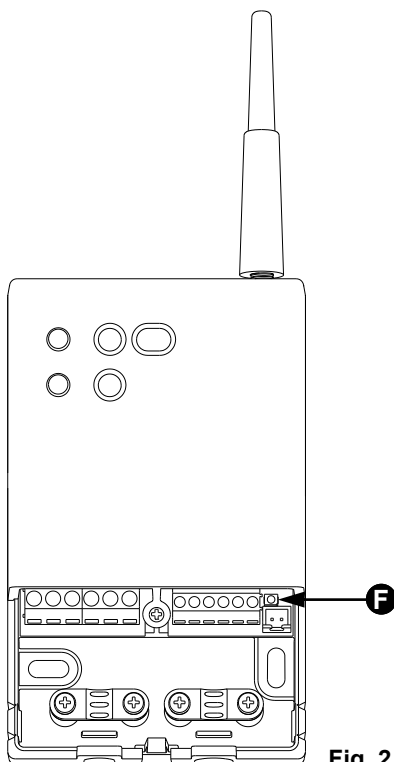

Fig. 2

MECHANICAL DESCRIPTION

Fig. 1 shows the exterior of the telephone interface.

GSM status LED "C"

This two-coloured LED indicates the device working status:

Fixed red: it indicates that the interface can not receive or send SMS due to no service of the GSM carrier.

The LED turns fixed red when:

- The device is powered and is initializing and registering in the GSM network. In this status commands can not be managed via SMS.
- There is no antenna.
- There is not enough signal, there is no communication with the mobile phone carrier.

Flashing red: it indicates that the interface can not receive or send SMS due to a problem with the SIM card. The LED turns flashing red when:

- The SIM card is not inserted.
- The PIN request in the SIM card has not been removed.
- The SIM card credit is insufficient.
- The SIM card is out of date.
- Error when SMS are sent due to a network congestion.

Yellow and Green: the device is connected to the GSM network and is ready to receive commands via SMS. The colour and the type of flashing indicate the intensity of the GSM signal:

- Fixed green: signal is excellent
- Flashing green: signal is good
- Fixed yellow: signal is fair
- Flashing yellow: signal is poor

OUT1 "D" and OUT2 "E" status LEDs

OUT1 and OUT2 status LEDs constantly display the status of the relevant outputs:

- on: output is on
- off: output is off

"F" diagnostic LED

This LED is visible only when the cable lid is taken off, since it is used for diagnostics only, in case of faults. The diagnostic LED flashes yellow when the interface is registered to the GSM carrier.

OUT 1 "A" OUT 2 "B" output buttons

On the front of the interface there are two buttons associated with the two outputs. Every time a button is pressed, the status of the relevant output is inverted, this allows manual ON/OFF switching.

"G" reset button

The left side of the interface features a slot to access to the reset button, which is used to force the reboot of the interface software or reset the factory default settings.

The reset button can be pressed without opening the interface's panel, simply inserting the tip of a screwdriver into the slot of the button, indicated as G in Fig. 3.

For further information, please see the paragraph "RESET BUTTON".

INSTALLATION



WARNING!

Before installing the telephone interface, find the best position and make sure there is a good signal of the GSM operator. See the paragraph "GSM COVERAGE CHECK".

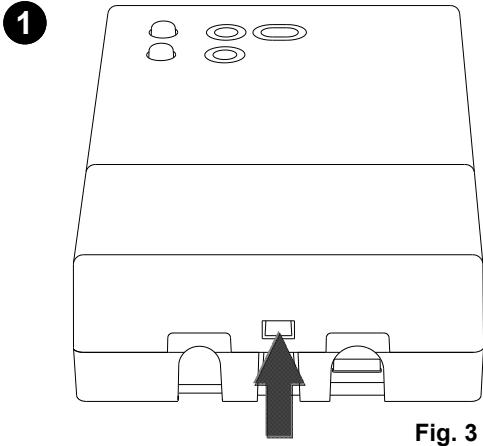

Fig. 3

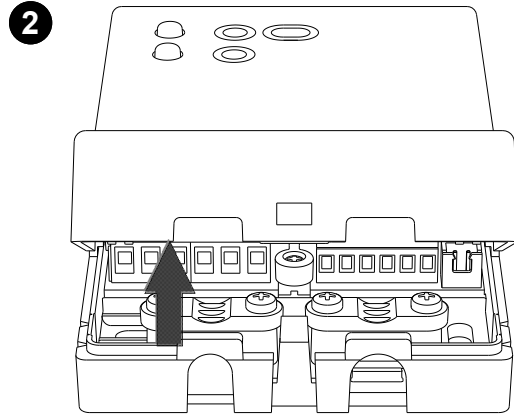

Fig. 4

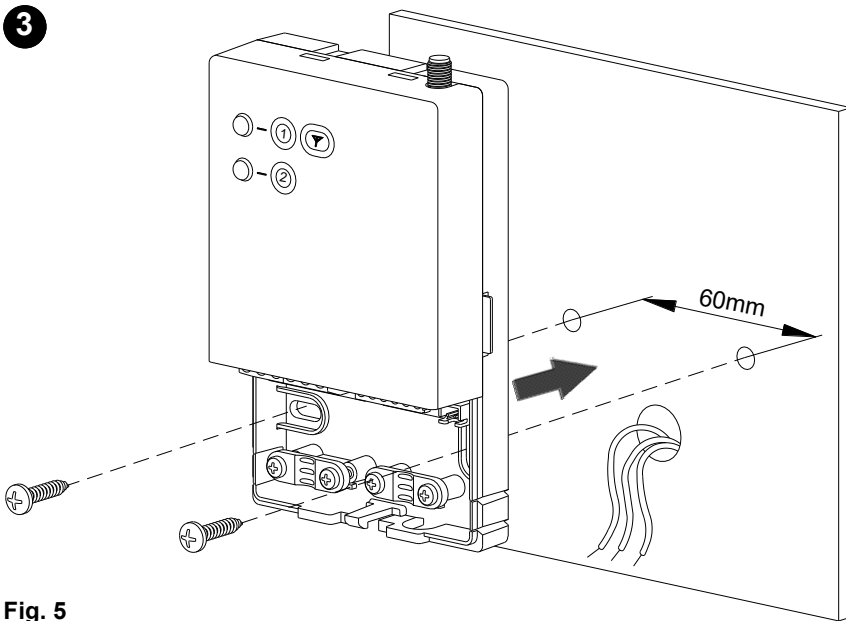

Fig. 5

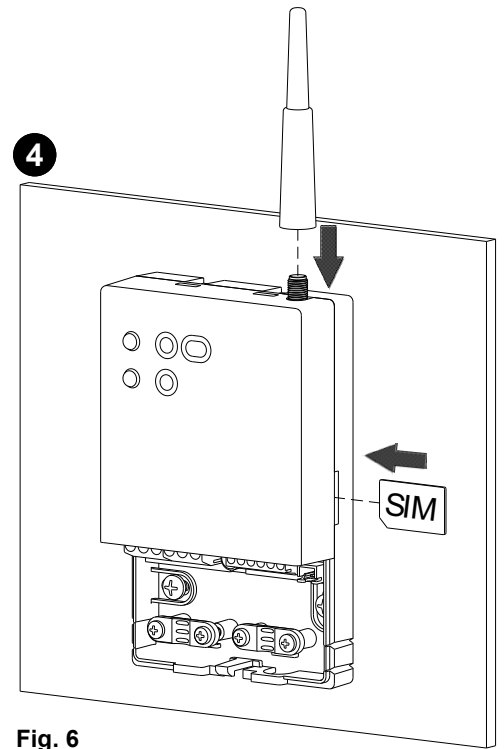

Fig. 6

5 Make the electrical connections.

WIRING DIAGRAM

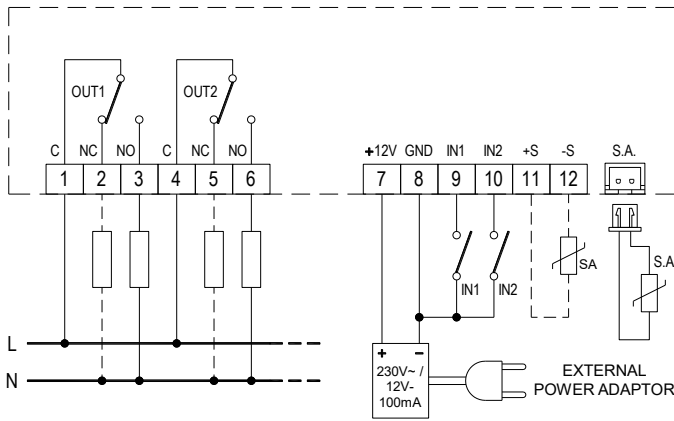

Fig. 7: Connection diagram.

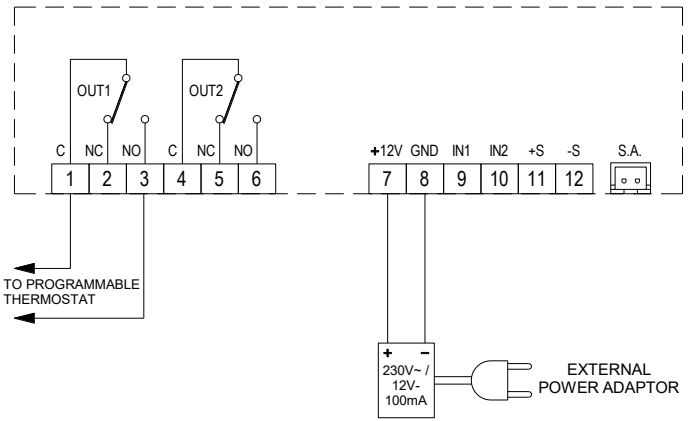

Fig. 8: Example of connection to a programmable thermostat.

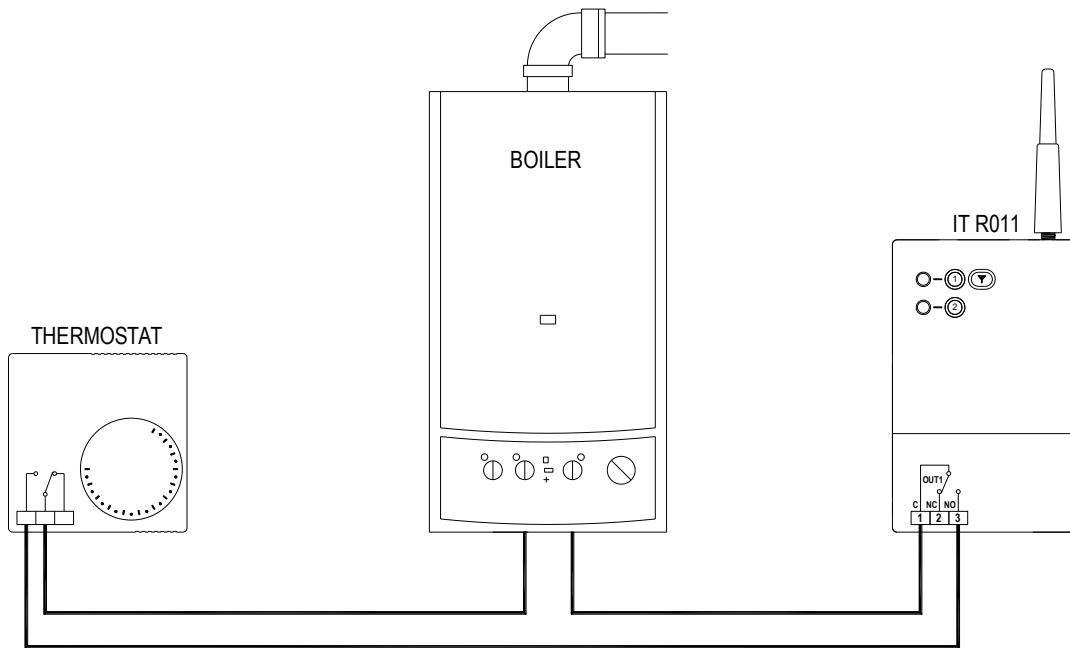

Fig. 9: Example of the telephone interface connected in series with a thermostat.

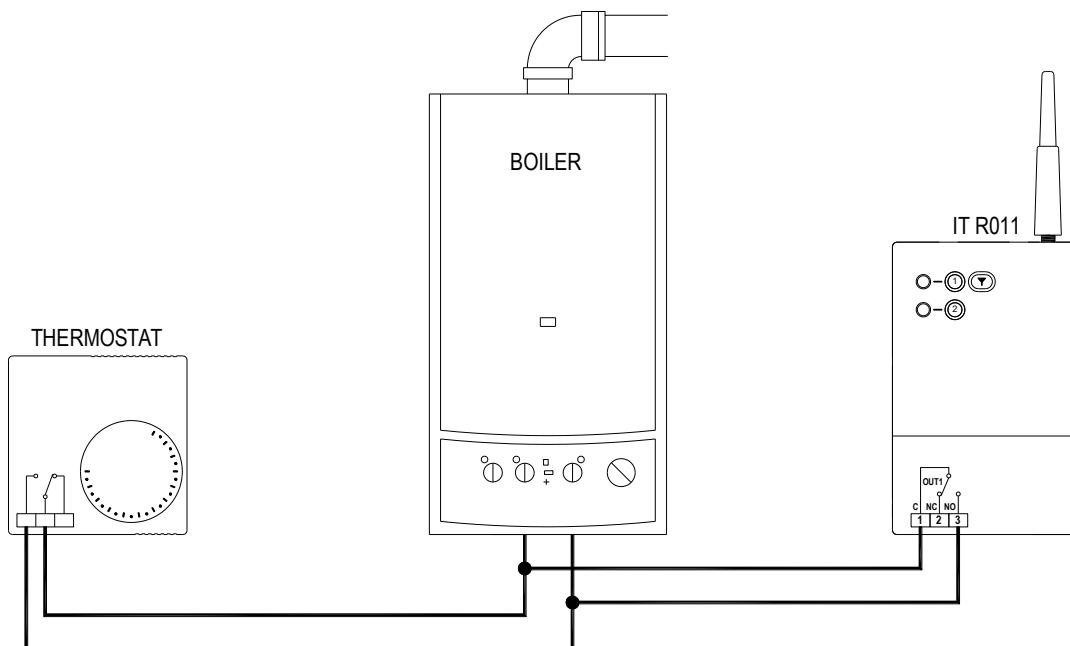

Fig. 10: Example of the telephone interface connected in parallel with a thermostat.

BATTERY INSERTION



WARNING!

Before inserting the batteries, fully install the telephone interface as described in the paragraph "Installation" and make sure that it works correctly with a 12V power adaptor. Also make sure that the final SIM card is inserted and that there is a sufficient signal coverage of the GSM carrier in its final position.

6

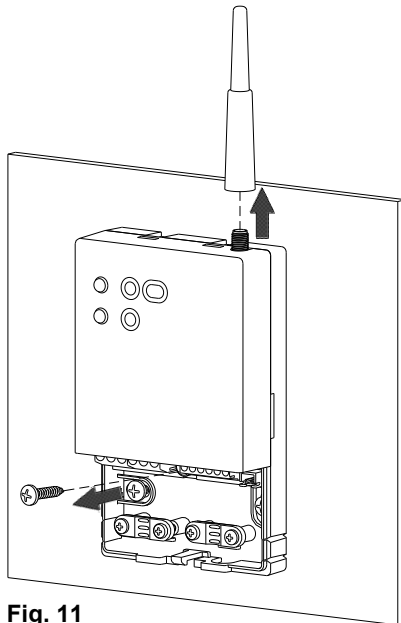

Fig. 11

7

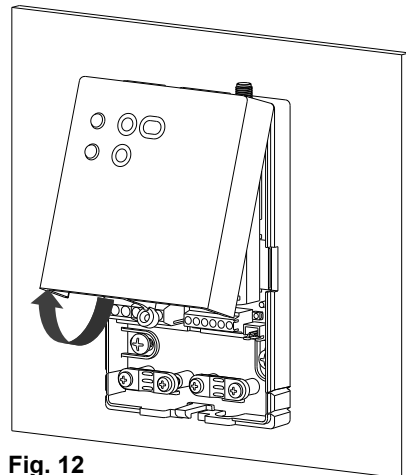

Fig. 12

8

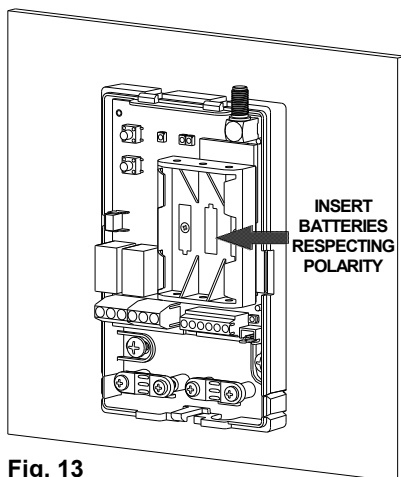

Fig. 13

9

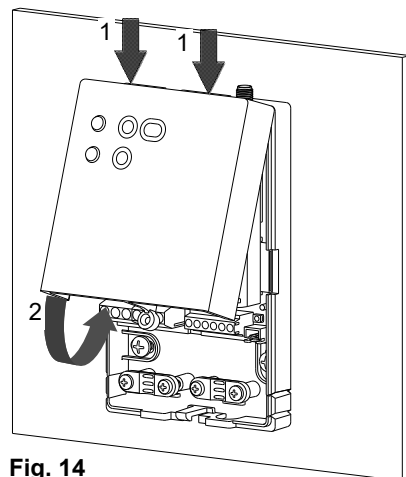

Fig. 14

10

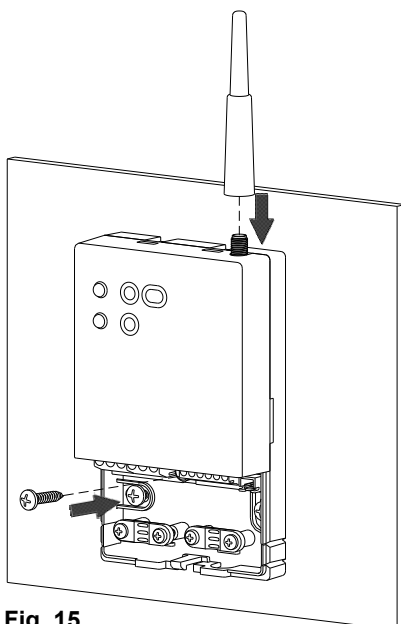

Fig. 15

11

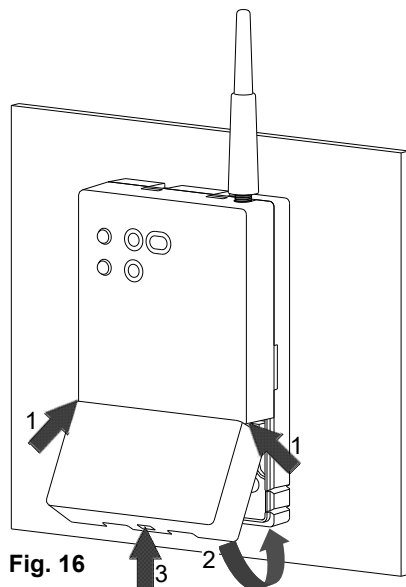

Fig. 16

GENERALITIES

This device is a telephone interface capable of switching one or two electric devices on and off from any distance via a GSM mobile phone network. It can be used to control burners, programmable thermostats, air conditioning systems and small irrigation systems, etc.

The interface works with a SIM card, which supports 2G technology, that is inserted inside it and accepts SMS commands from users memorised in the contact list or password-based commands; all SMS messages received from unrecognised users or containing command errors are ignored and deleted. Furthermore, the telephone interface can send SMS alarm messages to the phone numbers of the contact list in case of certain events, such as the change in the status of an input or a too low or too high room temperature or in case of mains power interruption or mains power return.

The telephone interface can receive commands from a mobile or fixed telephone or another device (computer or alarm system) provided it has the capability of sending SMS messages. By means of simple SMS messages you can command up to two external devices or check the status of the two outputs and the two inputs, as well as getting a room temperature reading.

The interface has a non-volatile memory enabling it to retain information about its current status and resume operating in the same status even after a power interruption.

Two pushbuttons on the front of the interface allows to change over the output status manually. The status is visually indicated by two LEDs (OUT 1 and OUT 2).

The two-colour GSM status LED (◐◑) lets you know at all times whether the interface is connected to GSM network or not and also provides an indication of signal strength.

Advanced functions make it possible to regulate the room temperature, via an external sensor, or protect the interior by means of the antifrost function.

Glossary

GSM: "Global System for Mobile Communications", an international standard for digital mobile telephony.

SMS: "Short Message Service" permits you to send or receive messages of up to 160 characters using mobile phones or fixed telephones that support this function.

SIM: "Subscriber Identity Module" it is the smart card inserted in each GSM phone and contains the protocols for connecting to the network of the mobile phone carrier, the subscriber's personal data, SMS messages and contact list. It may be in ISO format (the size of a standard credit card) or the Plug-in type.

GSM COVERAGE CHECK

The GSM status LED (◐) allows to check the intensity of the GSM signal. Alternatively, this information can be obtained via the "STATUS" command ("SIGNAL" line).

It is suggested to check the GSM signal intensity several times and at different hours to have an idea of the average behaviour.

If the signal is poor, install the interface in a better position for the radio reception. Alternatively, install an external antenna with an extension cable. The cable of the external antenna must be screwed onto the connector in place of the whip antenna supplied with the interface.

WARNING

If the interface does not respond to commands, most likely this could be due to a poor reception of the GSM signal. Please evaluate the possibility to install an external antenna to increase reception and improve reliability.

PREPARING THE SIM CARD

Before placing the SIM card in the telephone interface, you must insert it into a mobile phone and carry out the following steps:

- Deactivate the **PIN CODE** prompt.
The telephone interface can only work with SIM cards that do not request a PIN code when the device is switched on.
- *If you do not know the phone number associated to the SIM CARD, make a call to a phone to display it.*

It is not necessary to remove all the phone numbers of the SIM contact list.

INSTALLATION

To install the device, follow these steps and look at the pictures of page 2, 3 and 4:

WARNING: Identify the best position for installing the telephone interface, making sure to check that the GSM carrier signal strength is good.

For installation it is necessary to access the internal parts.

- ① Using a screwdriver, push the plastic flap of the bottom slot and slightly lift the cable lid up (Fig. 3).
- ② Rotate the cable lid and remove it completely (Fig. 4).
- ③ Fix the plate onto the wall using the two screw housings with a 60 mm centre-to-centre distance (use the screws and/or dowels supplied), and let the wires pass through the rectangular openings (Fig. 5).

WARNING: When working with tools in the vicinity of the screw holes, be careful not to damage the internal electronic circuits.

- ④ Screw the antenna supplied onto the connector and insert the SIM card in the telephone interface, after suitably preparing it as described in the paragraph: "**PREPARING THE SIM CARD**" (Fig. 6).

WARNING: Disconnect the telephone interface from the power supply before inserting or removing the SIM card.

- ⑤ Make the electrical connections according to the most suitable wiring diagram (see Fig. 7 - 8 and the paragraph "electrical connections").

BATTERY INSERTION

WARNING!

Before inserting the batteries, fully install the telephone interface and make sure that it works correctly with the 12V power adaptor. Also make sure that the final SIM card is inserted and that there is a sufficient signal coverage of the GSM carrier in its final position.

- ⑥ Remove the antenna and unscrew the screw blocking the cover onto the base (Fig. 11).
- ⑦ Rotate the cover and slightly press it until you take it off completely (Fig. 12).
- ⑧ Insert the batteries supplied according to the correct polarity (Fig. 13).

Close the interface following these steps:

- ⑨ Place the cover on the base so that the two teeth of the upper part matches the relevant slots and rotate the cover towards the base.
- ⑩ Insert the screw blocking the cover onto the base and screw the antenna onto the relevant connector (Fig. 15).
- ⑪ Place the cable lid on the base and rotate it towards the base; push the cable lid until the locking plastic flap springs into the hole on the lower side of the cable lid (Fig. 16).

ELECTRICAL CONNECTIONS

Follow the connection layout shown in Fig. 7.

The changeover contacts of the relays of the two outputs are available at terminals 1 .. 6. The relay contacts are voltage free and it is possible to activate loads as shown in the diagram. An external temperature sensor can be connected either to terminals 11 and 12 or the SA connector.

Terminals 9 and 10 are respectively inputs IN1 and IN2, whose status is acquired by the interface. It is possible to connect any electrical contact to these inputs, as indicated in the diagram.

However, it is important to use a voltage free contact, i.e. one connected only to the interface and not to other electrical equipment.

Terminals 7 and 8 are the inputs to which you must connect the 230V~/12V power adaptor (supplied); connect the positive wire, usually marked with a white stripe, to terminal 7.

If you want to connect the telephone interface to a programmable thermostat with an input dedicated to the interface, connect the 2 wires originating from the programmable thermostat as shown in the diagram in Fig. 8. If you want to control a system remotely using a simple thermostat or programmable thermostat not provided with an input dedicated to the telephone interface, it is possible to connect the interface in 2 ways, which result in slightly different operating modes:

Connection in series (Fig. 9): OUT1 must be in the ON status in order to turn on the burner and permit regulation of the temperature via the thermostat. To disable the temperature regulation function, you must turn OUT1 OFF. The thermostat setpoint should always be left on the "comfort" temperature. If you want to use the antifrost function, you must enable it from the interface by giving the ANTIFROST command.

In this case it is necessary to install the temperature sensor in the room whose temperature you wish to regulate.

Connection in parallel (Fig. 10): OUT1 must be in the OFF status in order to regulate temperature via the thermostat. To disable the regulation function either turn off the thermostat or turn the setpoint adjustment dial to minimum. To turn it on remotely, send the "REGULATE" command to the interface, which will regulate the temperature to the desired value. When you want to go back to regulating the temperature with the thermostat, you must turn it on or raise the setpoint and switch OUT1 of the interface to OFF. If desired, the antifrost function can be obtained by means of the thermostat, for example by turning the setpoint adjustment dial to minimum. Alternatively you can enable it through the telephone interface by giving the ANTIFROST command; in this case it is necessary to install the temperature sensor in the room whose temperature you wish to regulate.

EXTERNAL TEMPERATURE SENSOR

To be able to get a room temperature reading it is necessary to connect an external sensor to the "SA" connector (Fig. 7) or, alternatively, connect the 2 wires to terminals 11 and 12.

The type of probe to be used is a NTC with 10KOhm at 25°C and the maximum permitted length of cables is 3 metres.

OPERATION

When you turn the device on, the LEDs on the front will turn on for a few seconds in a non significant way. Then the LEDs OUT1 and OUT2 will flash red together with the yellow GSM LED for 3 times. After the initial flashing, the LEDs OUT will display the status of the outputs and the LED GSM will turn red to indicate that the interface is registering to the GSM carrier. After a few seconds, the GSM LED will turn green or yellow, based on the intensity of the signal, to indicate that the registration to the GSM carrier is complete.

RELIABILITY

In typical conditions of use, the telephone interface remains in stand-by for long periods of time, waiting for commands via SMS. During these periods the mobile phone carrier may decide to "unregister" the interface due to extended inactivity and cut off GSM communication.

To keep the communication always enabled, the device automatically carries out a software reboot cycle and a re-registration every 24 hours: in this way communication is kept enabled all the time.

During the "Reset" the outputs are turned off for a few seconds and then they will return to the original status.

Both the output status and configuration are retained also in

the event of a mains power failure.

RESET BUTTON

If you need to force a software reboot of the interface, the Reset button **G** can be pressed with a screwdriver. Alternatively, if batteries are not installed, the 12V power supply can be cycled.

If the batteries are installed, cycling 12V power supply will not force a software reboot since batteries will keep the interface powered; in this case the Reset button must be pressed.

The Reset button also allows to reset the factory default settings, which can be used, for example, when you forget your access password. To reset the factory default settings, push and hold for a few seconds the Reset button, until you see the sequence GREEN-RED-GREEN-RED on the GSM status LED.

Data stored will be reset as shown in Table 1.

Table 1:

Factory default settings that can be restored by holding the reset button.

FUNCTION	FACTORY DEFAULT SETTING
Password	123456
Language	Italian
Allarm TMIN	Enable 5°C
Allarm TMAX	Disable
Allarm IN1	Disable
Allarm IN2	Disable
Allarm Power	Enable
Setreport	ON

CHARGING THE BATTERIES

After inserting the batteries, when the interface is powered for the first time (12V), a 16-hour battery charging cycle will start. Afterwards, batteries will be kept charged with trickle charges. After a power interruption, batteries will be charged up to reset the charge lost during the black-out.

Make sure the interface is running with a 12V power adaptor and that the final SIM card is inserted before installing batteries, since turning off and then back on the interface would restart another 16-hour charging cycle. Repeated charging cycles on already charged batteries make them warm up and possibly deteriorate.

Also the Reset button restarts a 16-hour charging cycle.

If you need to turn off or reboot the interface and you want to skip the battery charging cycle, simply power the interface at 12V without inserting the batteries, wait for 2 minutes so that the interface detects missing batteries and then insert the batteries.

BATTERY OPERATION

When batteries are inserted, the interface will remain off, it is necessary the 12V power supply for the interface to turn on. Once it is on, if the 12V power supply is interrupted, the interface will stay on because it is powered by batteries, however the two outputs and the relevant LEDs will be turned off and their status can not be modified with the OUT1 and OUT2 buttons. The outputs are turned off to save the battery energy since also the driven outputs will be off due to mains power missing.

In this status the interface is still connected via GSM to send SMS alarm messages and to respond to users' commands. Also, when the device is running on batteries it is possible to modify the status of outputs with the commands TURN ON and TURN OFF, however, the outputs can be physically turned on only when mains power returns. The batteries operation autonomy depends on the GSM communication traffic and on the signal intensity and it is typically 25 hours.

If batteries are completely discharged, the interface will turn off and can not respond to the SMS commands.

When the interface is off or not registered to the GSM carrier, the GSM carrier will still keep the commands sent via SMS for a few days.

As soon as the interface is connected again, it will receive all the messages that have been stored over the past days. Therefore, should there be a prolonged power cut off or fault, it is normal to receive multiple responses to commands sent a long time ago.

TECHNICAL FEATURES

Power supply:	12V $\overline{\text{---}}$ (10 .. 16V $\overline{\text{---}}$)
Electrical input:	1,3W Max
Frequency:	900 - 1800 MHz Dual Band
Antenna type:	SMA M screwable whip antenna
Range of adjustment:	0.0 .. 32.0 °C
Antifrost range:	0.0 .. 18.0 °C
Measuring range:	-20.0 .. 55.0 °C
Sensor type:	NTC 10K @25°C \pm 1%
Precision:	\pm 1.0°C
Resolution:	0.1°C
Regulation hysteresis:	0.5 °C
Alarm hysteresis:	1.0 °C (per 60 sec)
External sensor:	NTC 10K @25°C \pm 1%
Length of ext. sensor wires:	3 m MAX
Contact rating:	2 x 3A @ 250V~ SPDT
Digital inputs:	2
Analog inputs:	1 for external NTC sensor
Buffer batteries:	3xAAA NiMh 1,2V 800..1000 mAh
Protection rating:	IP 3X
Operating temperature:	-20 .. +55 °C
Storage temperature:	-20 .. +55 °C
Humidity limits:	20 .. 80 % RH non condensante
Battery operating temperature NiMh :	0 .. +45 °C
Enclosure: Material:	ABS V0 self-extinguishing
Colour:	Signal white (RAL 9003)
Weight:	~ 556 gr.
Installation:	Wall mounted

DIMENSIONS (in mm)

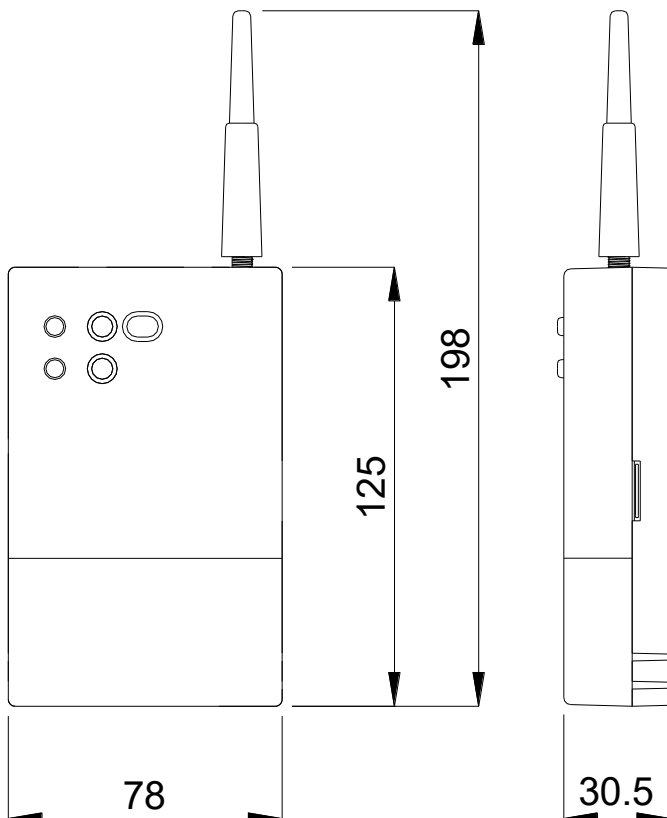

NORMATIVE REFERENCES

The product complies with the following standards:

EMC (2014/30/EU) - LVD (2014/35/EU):	EN 60730-1 (2011)
R&TTE (1999/05/EU):	EN 301 489-1 V1.8.1 (2008)
	EN 301 489-7 V1.3.1 (2005)
	EN 301 511 V9.0.2 (2002)

⚠ WARNING

- This device has been designed to work complete with a SIM card and antenna. Do not keep the device on for long periods of time if the SIM card or antenna are missing.
- This device is a low power radio transceiver. When switched on, it transmits and receives radiofrequency energy.
- The device may cause interference if operated in proximity to radios, television sets, telephones or electronic equipment in general.
- The device may in turn be subject to interference that can affect its performance.
- Do not position the device in proximity to medical equipment.
- Do not use the device in contact with the human body (and anyway with a distance not minor than 20cm) and do not touch the antenna unless strictly necessary.
- The device works by using a radio signal: no mobile phone carrier is able to guarantee a connection at all times.
- To ensure correct regulation of room temperature, it is recommended to install the sensor away from sources of heat, draughts or particularly cold walls (thermal bridges).
- To connect the sensor use cables with a minimum cross-section size of 1.5 mm² and maximum length of 25 m. Do not pair the cables in ducts with the mains power lines.
- Connect the device to the mains power supply via an omnipolar switch complying with current regulations and having a contact gap of at least 3 mm in each pole.
- Device installation and electrical connections must be entrusted to qualified personnel and must comply with the laws in force.
- Before making any connections make sure the mains power is disconnected.

WARRANTY

In view of its commitment to continuous product development, the manufacturer reserves the right to change technical and performance specifications without notice. Consumers are protected by a warranty against product nonconformities in accordance with European Directive 1999/44/EC and the manufacturer's warranty policy. The complete text of the warranty is available from the dealer on request.

DESCRIPTION OF COMMANDS

The commands for controlling the telephone interface are described in detail below. They represent the text to be written in the SMS message.

All commands must be preceded by the password if the phone number the message is being sent from is not recorded in the contact list. The factory default password is "123456" and can be changed by means of a specific command.

Example if not recorded: 123456 TURNON

Example if recorded: TURNON

WARNING

- When composing the text of command messages it is important to abide by the rules of syntax, including blank spaces.
- In the commands illustrated below, the _ symbol stands for a blank space.
- Command texts can be either in capital or small letters.
- In the case of temperatures either a dot or comma can be used as the decimal separator.
- Each SMS message may contain only one text command.

TURNON-TURNOFF: activates or deactivates relay outputs

With the " TURNON " and " TURNOFF " commands you can activate or deactivate an output.

The message to be sent to the telephone interface is the following:

Activate OUT1: **TURNON_OUT1**

Activate OUT2: **TURNON_OUT2**

Deactivate OUT1: **TURNOFF_OUT1**

Deactivate OUT2: **TURNOFF_OUT2**

The name of the output can be omitted: in this case output OUT1 will always be turned on or off.

TURNON TURNOFF

If alternative names have been associated with the 2 outputs via the " NEWNAME " command - for example, the name "BURNER" has been associated with OUT 1 - more intuitive commands can be sent, like:

TURNON_BURNER TURNOFF_BURNER

ON/OFF SWITCHING VIA A CALL

If a phone number is recorded among the contacts, the status of output OUT1 can be switched simply by making a call from that number to the telephone interface. It will "hang up" on recognising the user and perform the operation while saving the cost of an SMS message.

In any case, even if SETREPORT is OFF, a message will be sent as notification that the status has been switched.

STATUS: system status

The " STATUS " command allows you to interrogate the interface in order to find out the current status of the outputs and inputs and obtain other information about the device.

The message to be sent to the interface is the following:

STATUS

The interface will send a message reporting its current status.

Below is an example of a possible return message:

```
STATUS - TEMP. 15.4C
CALDAIA ON
OUT2 OFF
REGULATE 22.0C 2H30M
ANTIFROST 5.0C
IN1 OPEN
IN2 CLOSE
SIGNAL GOOD
```

CREDIT 124 POWER YES

TEMP indicates the temperature measured by the probe in degrees centigrade. The output OUT1, also known as "CALDAIA" is on, while OUT2 is off. The "Regulate" function is enabled and will adjust the temperature to 22°C for 2 and a half hours.

The "Antifrost" function is enabled at 5°C. The IN1 input is open, while the IN2 input is closed.

The GSM signal intensity is good. Whenever the interface is connected in "Roaming" mode, "(R)" will be displayed at the end of the signal line.

The credit function is enabled and there is enough credit for other 124 SMS.

POWER YES indicates that there is the 12V power supply and therefore there is mains power.

Note: In the reply message the REGULATE, ANTIFROST and CREDIT lines will not be shown if the respective functions are not enabled.

SETREPORT: Confirmation messages.

The telephone interface may be configured to respond to each command received with an SMS confirmation.

The message to be sent to the interface is the following:

To enable the sending of an SMS confirmation:

SETREPORT_ON

To disable the sending of an SMS confirmation:

SETREPORT_OFF

In the case of commands not associated with a specific response, an SMS confirmation with the following texts will be sent:

"COMMAND EXECUTED" o

"CONFIGURATION ACCEPTED"

if the command has been recognized and carried out.

SETPSW: Changing the password

Using the " SETPSW " command you can change the password for sending commands via the telephone interface.

The minimum length of the password is 4 characters, while the maximum length is 14 characters. It can include numbers and letters with no difference between upper and lower-case letters.

current password_SETPSW_new password

For example: **123456_SETPSW_ABCD12**

"123456" was the old password, now "ABCD12" becomes the new password.

ADD: add a phone number to the contact list

With this command you can record your phone number in the contact list of the interface so that you can send commands without having to enter the password each time.

You will also have to record the phone number of the users you want alarm messages to be sent to.

The contact list can contain up to a maximum of 10 names.

ADD_user name_phone number

For example: **ADD_JOHN_+393491234567**

In this manner the user " JOHN " associated with the phone number indicated will be memorised in the contact list.

It is important always to include the country calling code (+39 for Italy).

The name may be 14 characters long at the most.

REMOVE: remove a number from the contact list

REMOVE_phone number

For example: **REMOVE_+393491234567**

You can use this command to remove the phone number indicated from the contact list.

CONTACTS: view the numbers recorded in the contact list

CONTACTS

In response to this command the interface will send a message containing a list of all the recorded contacts. The name will be shown first, followed by the phone number. If the contact list includes more than 4 contacts, two or more SMS will be sent.

REGULATE: Regulation of room temperature.

The telephone interface is able to regulate the room temperature in heating mode when an external sensor is connected.

With the " REGULATE " command, the temperature and period of time (in hours) during which the temperature will be regulated, can be set.

The temperature can be set within the range of 0.0°C .. 32.0°C, whereas the time can be set from 1 to 48 hours.

The regulation function is always performed via OUT1 and therefore a heating device (burner) must be connected to that output.

REGULATE_temperature_time

The room temperature must be expressed in °C. The value can be expressed with or without the decimal, while the regulation time must be expressed in hours.

For example: REGULATE_20_12 or REGULATE_20.0_12

The two examples given are equivalent and will result in the room temperature being regulated to a setpoint of 20.0°C for a period of 12 hours.

If the interface is configured to send a confirmation message (SETREPORT ON), it will respond to the REGULATE command with the return message of the STATUS command.

To end the regulation period earlier than planned you can send a "TURNOFF OUT1" command (see "TURNON-TURNOFF" command) or manually change the status by means of the pushbutton on the front panel of the interface.

WARNING

The REGULATE command function is cancelled when:

- a command TURN ON or TURN OFF of the OUT1 output is received
- the OUT1 button is pushed
- a phone call to toggle OUT1 is received
- there is a 12V power interruption when the batteries are not installed

Therefore, it is important not to send commands relating to OUT1 during the room temperature regulation.

ANTIFROST: Enables the Antifrost function

When the antifrost function is enabled, the interface will activate output OUT1 if the room temperature falls below the set antifrost temperature (range 0.0°C .. 18.0°C) to protect both the room and the HVAC system.

In order for the function to work, a heating device must be connected to OUT1 and an external temperature sensor must obviously be connected as well.

ANTIFROST_temperature

The room temperature must be expressed in °C; the value may be expressed with or without the decimal.

For example: **ANTIFROST_5**

It enables the antifrost function on the OUT1 output with a 5°C threshold.

ANTIFROST OFF: Disables the Antifrost function.

ANTIFROST_OFF

It allows to disable the antifrost function.

The antifrost function remains enabled also when power is

cycled or when the OUT1 output is manually turned on or off with the button or the commands.

CALIBRATE: Sensor offset

If for any reason the room temperature measurement is not satisfactory, it is possible to correct it by means of the CALIBRATE command, which allows you to set a temperature offset of up to ±5.0°C, to be added to the actual room temperature reading.

The message must be composed as follows:

CALIBRATE_offset temperature

For example: **CALIBRATE_3,2**

3.2°C will be added to the room temperature measured by the sensor.

CREDIT: Credit low warning.

With the CREDIT command it is possible to set the amount of credit present in the SIM card and consequently receive an SMS warning message when the credit is about to run out. Credit must be expressed in the form of available SMS messages.

The number of available SMS messages is calculated by dividing the credit in Euros of the SIM card by the cost of sending a single SMS message. The maximum number of SMS messages that can be set is 9999.

CREDIT_number of available SMS

For example: **CREDIT_300**

Enables the function and sets a remaining credit of 300 SMS. The interface keeps track of the remaining credit, decreasing the total by one unit each time an SMS message is sent. When the credit level becomes 10, a warning message will be sent: "Warning, credit is 10 SMS".

In order for this function to be effective, you must remember to reset the credit level every time you recharge the SIM card.

CREDITO OFF: disables the CREDIT function

To disable the credit warning function, send a message containing the following command:

CREDIT_OFF

NEWNAME: Personalising the name of outputs and inputs

Using this command you can assign an alternative name to the 2 inputs and 2 outputs to make your commands more intuitive. The two relay outputs of the interface are called OUT1 and OUT2, whereas the 2 inputs are called IN1 and IN2.

The message to be sent to the telephone interface must be worded as follows:

NEWNAME_input/output_alternative name

For example: **NEWNAME_OUT1_BURNER
NEWNAME_OUT2_CLIMA
NEWNAME_IN1_PUMP
NEWNAME_IN2_WINDOW**

The alternative name may be up to 10 characters long and can also be used in the ALARM and MESSAGE commands.

The alternative names defined with NEWNAME will be used in responses to the STATUS command and can also be used in the place of OUT1 and OUT2 to specify the output in a turnon/turnoff command.

ALARM MANAGEMENT

The telephone interface can be configured to send SMS alarm messages.

Each time an alarm event occurs, a message will be sent to all the users in the contact list, specifying the type of event that has occurred.

The " ALARM " command allows you to set the operating mode to be associated with each individual alarm and the ON/OFF status.

Below is a description of the various types of alarms and the syntax to be used in the message should you wish to change the current configuration.

When an alarm is configured, if " SETREPORT " is enabled (ON), an SMS message specifying the alarm configuration status will be sent.

INPUTS ALARM

When this type of alarm is configured, the interface will monitor the status of the contacts connected to inputs IN1 and IN2.

Should there be a change in the status of the input as previously configured, the interface will send an SMS alarm message to all the users in the contact list.

ALARM_input_status_time_unit

Input: IN1
IN2
Status: OPEN
CLOSE
Time: 1 .. 255 range
Unit: (S) seconds
(M) minutes

Example: **ALARM_IN1_OPEN_3_S**

In this case an alarm message will be sent if IN1 switches from a closed status to an open one for at least 3 seconds.

Example: **ALARM_IN2_CLOSE_10_M**

In this case an alarm message will be sent if IN2 switches from an open status to a closed one for at least 10 minutes.

MINIMUM TEMPERATURE ALARM

Using this command you can set the minimum room temperature, within a range of -20°C .. +55°C, below which the telephone interface will send the corresponding alarm message.

The command sent to the interface must contain the following information:

ALARM_TMIN_temperature

Example: **ALARM_TMIN_10**

The minimum temperature set in this case is 10°C; the interface will generate an alarm message if the room temperature falls to 10°C or lower.

MAXIMUM TEMPERATURE ALARM

Using this command you can set the maximum room temperature, within a range of -20°C .. +55°C, above which the telephone interface will send the corresponding alarm message.

ALARM_TMAX_26

The maximum temperature set in this case is 26°C; the interface generates an alarm message if the room temperature raises to 26°C or above.

Important: Once a temperature alarm has been sent, the temperature must vary by at least 1°C for at least 1 minute in order for a new alarm message to be generated.

POWER INTERRUPTION ALARM

When this alarm is enabled, the interface will send a SMS alarm message in case of power supply interruption which is when the 12V power supply interrupts for at least 3 minutes.

Batteries must be installed for the electric power alarm to work. A message will be sent also on the power supply return, after 3 minutes of restored power. See the enable/disable command in the following paragraph.

ENABLING / DISABLING ALARMS

Each alarm may be individually enabled or disabled:

ALARM_alarm_type_status

Alarm type: IN1

IN2
TMIN
TMAX
POWER

Status: ENABLED
DISABLED

Examples: **ALARM_TMIN_ENABLED**
ALARM_TMAX_DISABLED
ALARM_IN1_ENABLED
ALARM_IN2_DISABLED
ALARM_POWER_ENABLED

If you want to know the alarm configuration, it is sufficient to send a message containing the word " **ALARM** " (without any parameter).

The interface will respond with a message like the ones in the examples below:

TMIN 5.0C ENABLED
TMAX 30.0C ENABLED
IN1 OPEN 3 S DISABLED
IN2 CLOSE 10 M ENABLED
POWER ENABLED
SETREPORT OFF

The response means:

- " minimum temperature " alarm enabled, with a threshold of 5.0°C;
- " maximum temperature " alarm enabled, with a threshold of 30.0°C;
- alarm when the contact of input IN1 remains open for at least 3 seconds, but the alarm is disabled;
- alarm when the contact of IN2 closes and remains closed for at least 10 minutes, the alarm is enabled;
- power interruption alarm enabled;
- the function of responding to each command with an SMS confirmation is disabled (OFF);

The device is factory configured with power interruption alarm enabled and TMIN alarm enabled at 5°C, while all the other alarms are disabled.

Alarm messages

On alarm events the device sends the following warning messages (default messages) to the registered users, according to the different types of alarm:

"Alarm temperature too low"
"Alarm temperature too high"
"Alarm IN1 input"
"Alarm IN2 input"
"Mains power interruption alarm"
"Mains power returned"

Using the " **MESSAGE** " command, the alarm messages can be personalised by defining a new text with a maximum of 60 characters:

MESSAGE_IN1_new message
MESSAGE_IN2_new message
MESSAGE_TMIN_new message
MESSAGE_TMAX_new message

For example: **MESSAGE_IN1_PUMP_ALARM**

" PUMP ALARM " becomes the text that will be used for the alarm associated with input IN1.

DEFAULT: Reset default.

The " **DEFAULT** " command resets all the parameters to factory default settings.

Default values are shown in Table 1 and Table 2.

DEFAULT

Table 1:

Factory default settings that can be restored by holding the reset button.

FUNCTION	FACTORY DEFAULT SETTING
Password	123456
Language	Italian
Allarm TMIN	Enable 5°C
Allarm TMAX	Disable
Allarm IN1	Disable
Allarm IN2	Disable
Allarm Power	Enable
Setreport	ON

Table 2:

Factory default settings that can be restored with the " DE-FAULT " command.

FUNCTION	FACTORY DEFAULT SETTING
Output OUT1	CALDAIA
Output OUT2	OUT2
Name IN1	IN1
Name IN2	IN2
Alarm message	Default
Contact	No contact
Temperature calibration	0.0 °C
Antifrost function	OFF
Credit function	OFF

VERSION: Firmware version

On receiving this command the interface will send a message containing the firmware version of the device.

VERSION

The response will be similar to this:

```
" VERSION - MANUFACTURER "Seitron S.p.A."
MODEL "SKE039 - SEITRON ITR011"
VERSION "1.0.0"
```

LANGUAGE

It is possible to modify the language of the interface commands. The interface will accept commands with different languages and moreover will respond to them and will send alarm messages in the set language.

The interface will not accept commands in a language that is different from the set language.

LANGUAGE_lingua

For example:

to set Italian: **LANGUAGE_ITA**

to set English: **LANGUAGE_ENG**

It is possible to choose the languages listed below.

Please refer to the instruction sheets of the relevant language for the command list.

```
Italian:   ITA
English:  ENG
French:   FRE
German:   GER
Spanish:  SPA
Polish:   POL
Swedish:  SWE
```

APP ITR MANAGER

In Google play store is freely available the application '**ITR Manager**' to control the telephone interface via Smartphone.

Note:

The application '**ITR Manager**' interfaces itself, through SMS, with telephonic actuators for GSM network manufactured by Seitron.



Table 3:
Summary of the configuration commands.

COMMAND	DESCRIPTION	EXAMPLE	
TURNON	Activates an output.	TURNON_OUT1	Activates OUT1.
TURNOFF	Deactivates an output.	TURNOFF_OUT2	Deactivates OUT2.
REGULATE	Enables the temperature regulation function.	REGULATE_22_10	Regulates heating on OUT1 at 22°C for 10 hours.
STATUS	Requests the status of inputs e outputs.	STATUS	An SMS message reporting the system status will be returned.
ANTIFROST	Enables the antifrost function.	ANTIFROST_4	OUT1 will be switched on in the event that the temperature falls below 4°C.
SETREPORT	Configures the sending of confirmation messages.	SETREPORT_ON	Enables the sending of confirmation messages.
ADD	Adds a contact.	ADD_JOHN_+3912345678	Adds JOHN and the respective phone number to the contact list.
REMOVE	Deletes a contact.	REMOVE_+3912345678	Delete the contact with the phone number indicated.
CONTACTS	Requests the contents of the contact list.	CONTACTS	An SMS message containing the list of contacts will be returned.
NEWNAME	Sets an alternative name for an input or output.	NEWNAME_OUT1_BURNER	In commands BURNER can be used in the place of OUT1.
ALARM	Configures an alarm as enabled or disabled.	ALARM_IN1_OPEN_3_s	An alarm will be generated if input IN1 opens for 3 seconds.
ALARM	Disables alarm IN1.	ALARM_IN1_DISABLED	Input IN1 will no longer generate alarm messages.
ALARM	Requests the current alarm configuration.	ALARM	An SMS message with the current alarm configuration will be returned.
MESSAGE	Sets a personalised alarm message.	MESSAGE_IN1_PUMP	"PUMP" becomes the text of the SMS message that will be sent on occurrence of the alarm.
CREDIT	Enables the credit function.	CREDIT_456	Sets a remaining credit of 456 SMS messages.
SETPSW	Changes the password.	123456_SETPSW_PIPPO	"PIPP0" becomes the new password.
DEFAULT	Restores factory default configuration.	DEFAULT	Return to the factory configuration with password "123456".
VERSION	Requests the device firmware version.	VERSION	An SMS specifying the firmware version of the interface will be sent.
LANGUAGE	Set the language.	LANGUAGE_ITA	The interface will respond to the commands in Italian.
CALIBRATE	Calibrates room temperature readings.	CALIBRATE_-3,0	An offset value of 3°C will be subtracted from the room temperature reading.