

COMBINED CIRCULATION UNIT FOR SOLAR APPLICATIONS



Please install the circulation group to a fix wall, not subject to vibrations. Please ensure that installation environment and connection devices are in compliance with existing laws. Please use the device with care and with the necessary protections. Do not damage existent cables, while drilling the wall. Empty the components that may contain hot water, activating any vents before their use. Reset all safety and control functions that can be affected by any intervention on the device and make sure that they function before their service.



Circulation unit is in tension. Before every maintenance operation please remove power supply. Do not damage electrical cables while drilling the wall. Please link electrical connections with the proper section conductors. Please protect connection cables in order to avoid their damage. Please use proper electrical equipments (ensure that feeder cables are in good conditions and that rotating or alternative motion parts are correctly set), use them correctly, do not obstruct motion with feeder cable and prevent drops from heights.

Main Parts:

1. **Thermometer on the supply side**, colour red, range 0–160° C
2. **Cock on the supply side DN 20**, with integrated bracket
3. **Connection pipe**, copper d.18
4. **Manual air vent**, hose end connection
5. **Air stop device**, manual integrated vent
6. **System connections**: olive \varnothing 15, 18, 22, $\frac{3}{4}$ "M, $\frac{3}{4}$ "F, 1"M, 1"F
7. **Hose end connection**, filing/flushing device, d.15
8. **Flowmeter**, flow rate regulation and graduated scale, regulation range 1-6, 2-12, 8-28, 8-38 lt/min
9. **Cock for filling/flushing of the unit**, connection $\frac{3}{4}$ "M with safety tap and chain.
10. **Circulator**, solar pump GRUNDFOS UPM3 Solar 15/75 – 130.
11. **Return cock DN 20**, with integrated bracket, connection $\frac{3}{4}$ "M always open on one side. Check valve activation: closure at 90° and opening at 45°.
Check opening 2kPa (200 mmc.a.)
12. **Safety group**, with safety valve 6 bar certified TUV according to SV 100 7.7 - Directive 97/23/CE, manometer range 0-10 bar, vertical threaded connection to expansion tank Rp $\frac{3}{4}$ "M ISO228 with flat gasket connection. Other pressures available on request.
13. **Thermometer on the return side**, colour blue, range 0-160°C
14. **Fixing stirrup**, front end retainer and safety screw.
15. **Isolation**, black ppe density 40 kg/m³, plain.

Dimensions

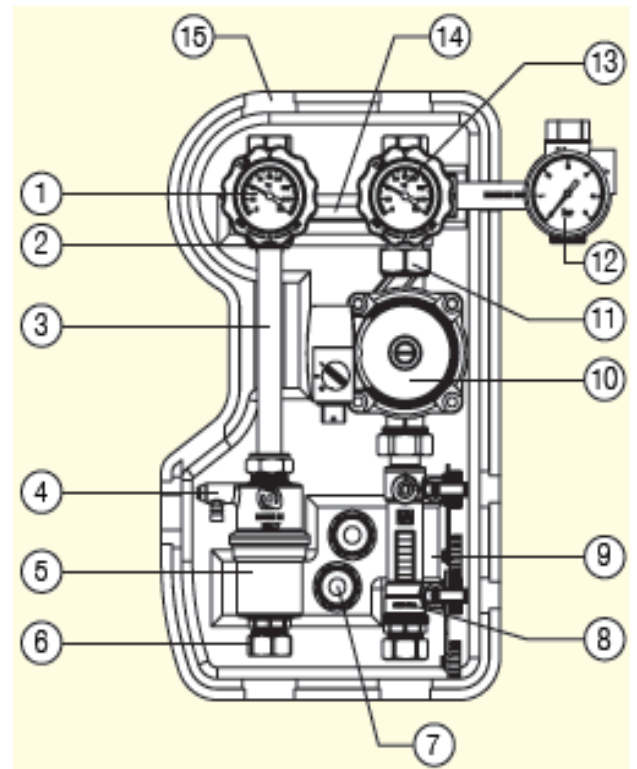
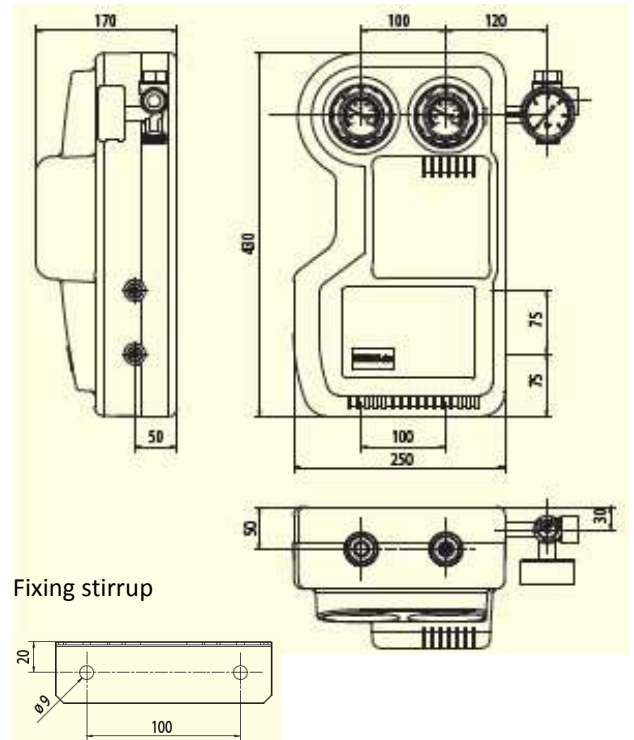

Installation:

Drill the wall with a nib d.8 mm and fix the fixing stirrup to the wall with the supplied brackets and screws. Should the supplied brackets not be suitable for the wall type, replace them with a proper model. Insert the back of the insulation cover on the fixing stirrup, paying attention to insert it completely. If necessary line the cover with a bubble level and then clamp the brackets definitively.

Set the supply and return sides by inserting the hook, which is located on the back of the cocks that are on the stirrup. Insert the safety clips in the lower part of the stirrup and fix them with the supplied screws.

This phase allows the completion of operations to the unit in maximum safety. Connect the supply and return pipes to the circulation unit.

Pre-set and connect a suitable expansion tank according to the device instructions and one drain for the safety valve, in order not to have any leakage of heat carrier fluid in the surrounding environment. After the washing, filling, electric connection and verification phases, please close the circulation unit with the front cover.

Device run-up

After having connected all the pipes, it is necessary to clean the device in order to eliminate any possible impurities.

Please proceed as follows:

- Close the balancing valve
- Connect to the filling connection, put water in the device and make it circulate until clean water comes out from the drain joint
- If for this operation water is used, please empty the device from the apposite joint, paying attention to forcing the opening of the check valve, by turning by 45° in closure the outlet valve (colour blue)
- Please repeat the filling operation with appropriate heat-carrying fluid (water and glycol max 50%)
- Place in working position all the hydraulic components and switch the circulator on
- After having opened the air vent valve on supply side, make the fluid circulate for some minutes, and then re-check the pressure of the device. If it is lower than estimated, put in some more fluid and repeat the vent operation
- Once the device has been deaerated, activate the pump at maximum speed and proceed with flow regulation according to the instructions given by solar collector supplier. Flow rate regulation is done through the activation of the balancing valve, the readout of the related indicator, or the action on the pump speed switch device.

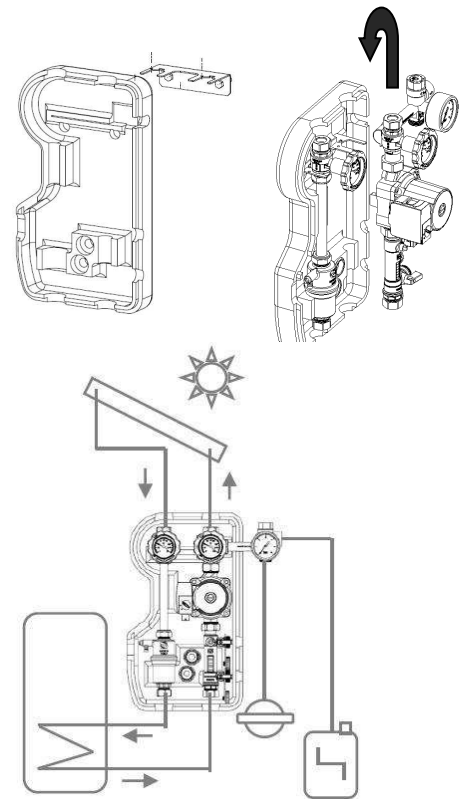

Anomalies

Should the pump not function, first of all make sure that the feeder cable is well connected, unscrew the central screw, and then unblock the rotor with a screwdriver. ATTENTION: rotor, like the other hydraulic components, might be hot. If the pump is noisy, make sure that there is no air in the circuit, if so repeat the run-up operations. If necessary increase the device pressure until the maximum pressure is reached, or decrease the pump speed so that it is adequate to the device characteristics.

Technical specifications

Fluid:	Water, glycol solution max 50%
Working temperature:	130°C – 150°C peak
Safety group:	6 bar, other pressures available
Manometer pressure range:	0÷10 bar
Thermometer temperature range:	0÷160°C
Minimum pressure for check valve opening:	Δp : 2 kPa (200 mm c.a.)
Flowmeter regulation range:	1-6, 2-12, 8-28, 8-38 lt/min
Connections:	olive $\varnothing 15$, $\varnothing 18$, $\varnothing 22$, $\frac{3}{4}$ " M, $\frac{3}{4}$ " F, 1" M e 1" F
Expansion vessel connections:	$\frac{3}{4}$ " M
Filling/ flushing connections:	$\frac{3}{4}$ " M; hose end $\varnothing 15$ mm
Pump power supply:	230 V - 50 Hz

We reserve the right to change or improve the above described product and its technical features at any time and without notice.